

Technical Information

Omnigrad S TR88, TC88

Modular Thermometer



TR88 with resistance insert (RTD)
TC88 with thermocouple insert (TC)
Extension neck and threaded connection for
installation in an existing thermowell

Application

- Universal range of application
- Suitable for installation in already existing thermowells
- Measuring range:
 - Resistance insert (RTD): -200 to 600 °C (-328 to 1 112 °F)
 - Thermocouple (TC): -40 to 1 100 °C (-40 to 2 012 °F)
- Degree of protection up to IP68

Head transmitter

All Endress+Hauser transmitters are available with enhanced accuracy and reliability compared to directly wired sensors. Easy customizing by choosing one of the following outputs and communication protocols:

- Analog output 4 to 20 mA
- HART®
- PROFIBUS® PA
- FOUNDATION Fieldbus™

Your benefits

- High degree of flexibility thanks to modular design with standard terminal heads as per DIN EN 50446 and customer-specific immersion lengths
- Variable total length in suitable thermowells thanks to compression fitting on extension neck
- Types of protection for use in hazardous locations:
 - Intrinsic Safety (Ex ia)
 - Non-sparking (Ex nA)

Function and system design

Measuring principle

Resistance thermometer (RTD)

These resistance thermometers use a Pt100 temperature sensor according to IEC 60751. The temperature sensor is a temperature-sensitive platinum resistor with a resistance of 100 Ω at 0 °C (32 °F) and a temperature coefficient $\alpha = 0.003851 \text{ } ^\circ\text{C}^{-1}$.

There are generally two different kinds of platinum resistance thermometers:

- **Wire wound (WW):** Here, a double coil of fine, high-purity platinum wire is located in a ceramic support. This is then sealed top and bottom with a ceramic protective layer. Such resistance thermometers not only facilitate very reproducible measurements but also offer good long-term stability of the resistance/temperature characteristic within temperature ranges up to 600 °C (1 112 °F). This type of sensor is relatively large in size and it is comparatively sensitive to vibrations.
- **Thin film platinum resistance thermometers (TF):** A very thin, ultrapure platinum layer, approx. 1 μm thick, is vaporized in a vacuum on a ceramic substrate and then structured photolithographically. The platinum conductor paths formed in this way create the measuring resistance. Additional covering and passivation layers are applied and reliably protect the thin platinum layer from contamination and oxidation, even at high temperatures.

The primary advantages of thin film temperature sensors over wire wound versions are their smaller sizes and better vibration resistance. A relatively low principle-based deviation of the resistance/temperature characteristic from the standard characteristic of IEC 60751 can frequently be observed among TF sensors at high temperatures. As a result, the tight limit values of tolerance category A as per IEC 60751 can only be observed with TF sensors at temperatures up to approx. 300 °C (572 °F).

Thermocouples (TC)

Thermocouples are comparatively simple, robust temperature sensors which use the Seebeck effect for temperature measurement: if two electrical conductors made of different materials are connected at a point, a weak electrical voltage can be measured between the two open conductor ends if the conductors are subjected to a thermal gradient. This voltage is called thermoelectric voltage or electromotive force (emf.). Its magnitude depends on the type of conducting materials and the temperature difference between the "measuring point" (the junction of the two conductors) and the "cold junction" (the open conductor ends). Accordingly, thermocouples primarily only measure differences in temperature. The absolute temperature at the measuring point can be determined from these if the associated temperature at the cold junction is known or is measured separately and compensated for. The material combinations and associated thermoelectric voltage/temperature characteristics of the most common types of thermocouple are standardized in the IEC 60584 and ASTM E230/ANSI MC96.1 standards.

Measuring system

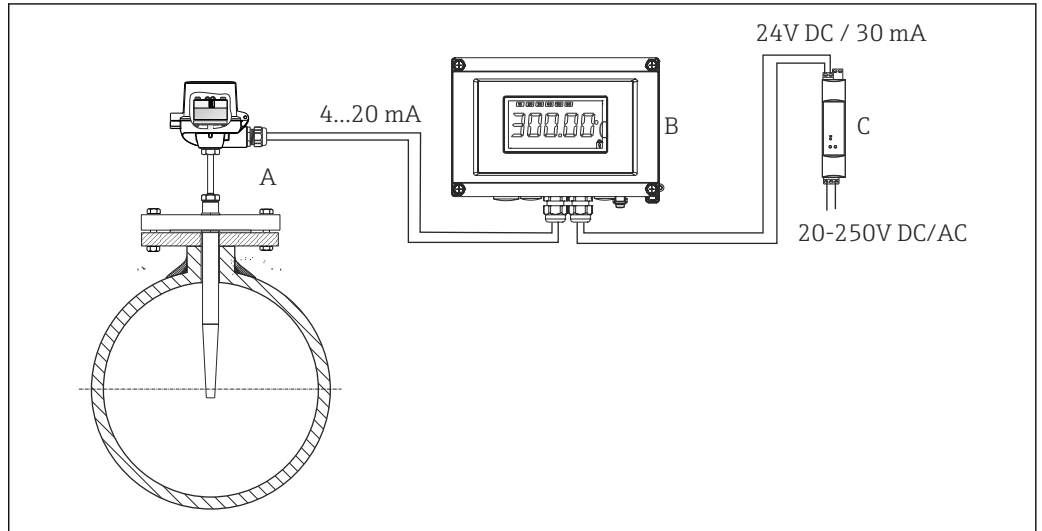

A0012641

1 Application example

- A Thermometer with fitted head transmitter mounted in an existing onsite thermowell
- B RIA16 field display unit - The display unit records the analog measuring signal from the head transmitter and shows this on the display. The LC display shows the current measured value in digital form and as a bar graph indicating a limit value violation. The display unit is looped into the 4 to 20 mA circuit and gets the required energy from there. More information on this can be found in the Technical Information (see "Documentation").
- C Active barrier RN221N - The RN221N (24 V DC, 30 mA) active barrier has a galvanically isolated output for supplying voltage to loop-powered transmitters. The universal power supply works with an input supply voltage of 20 to 250 V DC/AC, 50/60 Hz, which means that it can be used in all international power grids. More information on this can be found in the Technical Information (see "Documentation").

Equipment architecture

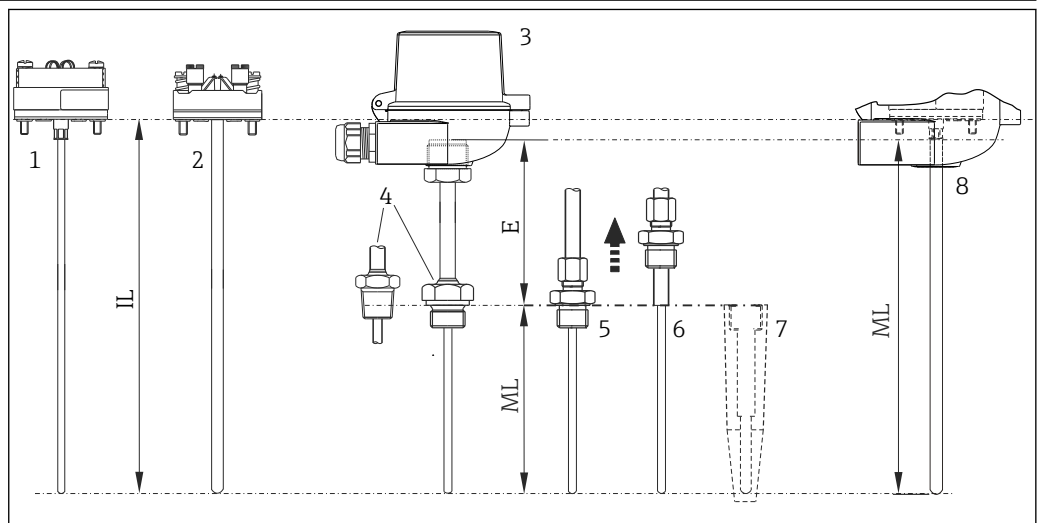

A0012672

2 Thermometer design

- 1 Insert with head transmitter mounted (example with $\phi 3$ mm (0.12 in))
- 2 Insert with terminal block mounted (example with $\phi 6$ mm (0.24 in))
- 3 Complete thermometer with terminal head
- 4 Thermowell connection: Threaded connection on extension neck
- 5 Thermowell connection: Adjustable compression fitting on the extension neck. Possible maximum length of the extension neck E as basic condition for the nominal calculation of the insertion length IL.
- 6 Thermowell connection: Adjustable compression fitting on the extension neck. The length E can be adjusted during the installation.
- 7 Existing onsite thermowell located in the process
- 8 Version without extension neck, if thermowell and extension neck are present on site in the process ($E = 0$ mm)
- E Length of extension neck
- IL Insertion length
- ML Insertion length for existing onsite components

Thermometers from the Omnigrad S TR88 and TC88 series have a modular design. The terminal head is used as a connection module for the mechanical and electrical connection of the insert. The position of the actual thermometer sensor in the insert ensures that it is mechanically protected. If installed in a thermowell the insert can be exchanged and calibrated without interrupting the process. The insert has flying leads, a ceramic connection socket or mounted temperature transmitter. The thermometers are designed for installation in an existing onsite thermowell. Different threaded connections are available on the bottom of the extension neck for installation in the thermowell. Insofar as the thermowell is suited to this purpose, the thermometer may also be mounted using a suitable compression fitting on the extension neck. This means that thermometers with a fixed insertion length (ML) can be used variably, even in thermowells of varying length, and can be installed in such a way that an optimum thermal contact is guaranteed between the tip of the insert and the bottom of the thermowell.

Measurement range	■ RTD: -200 to 600 °C (-328 to 1 112 °F)
	■ TC: -40 to 1 100 °C (-40 to 2 012 °F)

Performance characteristics

Operating conditions

Ambient temperature range

Terminal head	Temperature in °C (°F)
Without mounted head transmitter	Depends on the terminal head used and the cable gland or fieldbus connector, see 'Terminal heads' section
With mounted head transmitter	-40 to 85 °C (-40 to 185 °F)
With mounted head transmitter and display	-20 to 70 °C (-4 to 158 °F)

Process pressure

The maximum process pressure depends on the thermowell into which the thermometer is screwed. For an overview of the Endress+Hauser thermowells which may be used, see →  22.

Permitted flow rate as a function of immersion length

The maximum permitted flow rate to which the thermometer can be subjected, reduces the greater the immersion depth of the thermowell in the flowing medium. In addition, it is dependent on the diameter of the tip of the thermowell, the medium type, process temperature and process pressure. For an overview of the Endress+Hauser thermowells which may be used, see →  22.

Shock and vibration resistance

The Endress+Hauser inserts meet the requirements of IEC 60751 which specify shock and vibration resistance of 3g in the range from 10 to 500 Hz. The vibration resistance at the measuring point depends on the sensor type and design, see the following table:

Version	Vibration resistance for the sensor tip
Pt100 (WW or TF)	30 m/s ² (3g)
iTHERM StrongSens Pt100 (TF)	> 600 m/s ² (60g)

Accuracy

Permissible deviation limits of thermoelectric voltages from the standard characteristic for thermocouples as per IEC 60584 or ASTM E230/ANSI MC96.1:

Standard	Type	Standard tolerance		Special tolerance	
		Class	Deviation	Class	Deviation
IEC 60584	J (Fe-CuNi)	2	$\pm 2.5\text{ }^\circ\text{C}$ (-40 to 333 $^\circ\text{C}$) $\pm 0.0075 t ^{1)}$ (333 to 750 $^\circ\text{C}$)	1	$\pm 1.5\text{ }^\circ\text{C}$ (-40 to 375 $^\circ\text{C}$) $\pm 0.004 t ^{1)}$ (375 to 750 $^\circ\text{C}$)
	K (NiCr-NiAl)	2	$\pm 2.5\text{ }^\circ\text{C}$ (-40 to 333 $^\circ\text{C}$) $\pm 0.0075 t ^{1)}$ (333 to 1200 $^\circ\text{C}$)	1	$\pm 1.5\text{ }^\circ\text{C}$ (-40 to 375 $^\circ\text{C}$) $\pm 0.004 t ^{1)}$ (375 to 1000 $^\circ\text{C}$)

1) |t| = absolute value $^\circ\text{C}$

Standard	Type	Standard tolerance	Special tolerance
ASTM E230/ANSI MC96.1		Deviation, the larger respective value applies	
	J (Fe-CuNi)	$\pm 2.2\text{ K}$ or $\pm 0.0075 t ^{1)}$ (0 to 760 $^\circ\text{C}$)	$\pm 1.1\text{ K}$ or $\pm 0.004 t ^{1)}$ (0 to 760 $^\circ\text{C}$)
	K (NiCr-NiAl)	$\pm 2.2\text{ K}$ or $\pm 0.02 t ^{1)}$ (-200 to 0 $^\circ\text{C}$) $\pm 2.2\text{ K}$ or $\pm 0.0075 t ^{1)}$ (0 to 1260 $^\circ\text{C}$)	$\pm 1.1\text{ K}$ or $\pm 0.004 t ^{1)}$ (0 to 1260 $^\circ\text{C}$)

1) |t| = absolute value $^\circ\text{C}$

RTD resistance thermometer as per IEC 60751

Class	Max. tolerances ($^\circ\text{C}$)	Characteristics
Cl. AA, former 1/3 Cl. B	$\pm (0.1 + 0.0017 \cdot t ^{1)})$	
Cl. A	$\pm (0.15 + 0.002 \cdot t)$	
Cl. B	$\pm (0.3 + 0.005 \cdot t)$	
Temperature ranges for compliance with the tolerance classes		
Wire wound sensor (WW):	Cl. A	Cl. AA
	- 100 to +450 $^\circ\text{C}$	-50 to +250 $^\circ\text{C}$
Thin-film version (TF):	Cl. A	Cl. AA
	<ul style="list-style-type: none"> ■ Standard ■ iTHERM ■ StrongSens 	-30 to +300 $^\circ\text{C}$ 0 to +150 $^\circ\text{C}$ -30 to +300 $^\circ\text{C}$ 0 to +200 $^\circ\text{C}$

1) |t| = absolute value $^\circ\text{C}$

In order to obtain the maximum tolerances in $^\circ\text{F}$, the results in $^\circ\text{C}$ must be multiplied by a factor of 1.8.

Response time

Tested in accordance with IEC 60751 in flowing water (0.4 m/s at 30 °C):

Insert:

Sensor type	Diameter ID	Response time	Thin film (TF)
iTHERM StrongSens	6 mm (0.24 in)	t ₅₀	< 3.5 s
		t ₉₀	< 10 s
TF Sensor	3 mm (0.12 in)	t ₅₀	2.5 s
		t ₉₀	5.5 s
	6 mm (0.24 in)	t ₅₀	5 s
		t ₉₀	13 s
WW Sensor	3 mm (0.12 in)	t ₅₀	2 s
		t ₉₀	6 s
	6 mm (0.24 in)	t ₅₀	4 s
		t ₉₀	12 s
Thermocouple (TPC100) grounded	3 mm (0.12 in)	t ₅₀	0.8 s
		t ₉₀	2 s
	6 mm (0.24 in)	t ₅₀	2 s
		t ₉₀	5 s
Thermocouple (TPC100) ungrounded	3 mm (0.12 in)	t ₅₀	1 s
		t ₉₀	2.5 s
	6 mm (0.24 in)	t ₅₀	2.5 s
		t ₉₀	7 s



Response time for the sensor assembly without transmitter.

Insulation resistance

- RTD:
Insulation resistance according to IEC 60751 > 100 MΩ at 25 °C between terminals and sheath material measured with a minimum test voltage of 100 V DC
- TC:
Insulation resistance according to IEC 1515 between terminals and sheath material with a test voltage of 500 V DC:
 - > 1 GΩ at 20 °C
 - > 5 MΩ at 500 °C

Dielectric strength

Tested at a room temperature for 5 s:

- Ø6 mm (0.24 in): ≥ 1 000 V DC between terminals and insert sheath
- Ø3 mm (0.12 in): ≥ 250 V DC between terminals and insert sheath

Self heating

RTD elements are passive resistances that are measured using an external current. This measurement current causes a self-heating effect in the RTD element itself which in turn creates an additional measurement error. In addition to the measurement current, the size of the measurement error is also affected by the temperature conductivity and flow velocity of the process. This self-heating error is negligible when an Endress+Hauser iTMP temperature transmitter (very small measurement current) is connected.

Calibration

Endress+Hauser provides comparison temperature calibration from -80 to +1 400 °C (-110 to +2 552 °F) based on the International Temperature Scale (ITS90).

Calibrations are traceable to national and international standards. The calibration certificate is referenced to the serial number of the thermometer. Only the insert is calibrated.

Insert: Ø6 mm (0.24 in) and 3 mm (0.12 in)	Minimum insertion length of insert in mm (in)	
	without head transmitter	with head transmitter
-80 to -40 °C (-110 to -40 °F)	200 (7.87)	
-40 to 0 °C (-40 to 32 °F)	160 (6.3)	
0 to 250 °C (32 to 480 °F)	120 (4.72)	150 (5.91)
250 to 550 °C (480 to 1020 °F)	300 (11.81)	
550 to 1400 °C (1020 to 2552 °F)	450 (17.72)	

Material

Extension neck, insert and process connection.

The temperatures for continuous operation specified in the following table are only intended as reference values for use of the various materials in air and without any significant compressive load. The maximum operation temperatures are reduced considerably in some cases where abnormal conditions such as high mechanical load occur or in aggressive media.

Material name	Short form	Recommended max. temp. for continuous use in air	Properties
AISI 316L/ 1.4404 1.4435	X2CrNiMo17-12-2 X2CrNiMo18-14-3	650 °C (1 202 °F) ¹⁾	<ul style="list-style-type: none"> ■ Austenitic, stainless steel ■ High corrosion resistance in general ■ Particularly high corrosion resistance in chlorine-based and acidic, non-oxidizing atmospheres through the addition of molybdenum (e.g. phosphoric and sulfuric acids, acetic and tartaric acids with a low concentration) ■ Increased resistance to intergranular corrosion and pitting ■ Compared to 1.4404, 1.4435 has even higher corrosion resistance and a lower delta ferrite content
AISI 316Ti/ 1.4571	X6CrNiMoTi17-12-2	700 °C (1 292 °F)	<ul style="list-style-type: none"> ■ Properties comparable to AISI316L ■ Addition of titanium means increased resistance to intergranular corrosion even after welding ■ Broad range of uses in the chemical, petrochemical and oil industries as well as in coal chemistry ■ Can only be polished to a limited extent, titanium streaks can form
Alloy 600/ 2.4816	NiCr15Fe	1 100 °C (2 012 °F)	<ul style="list-style-type: none"> ■ A nickel/chromium alloy with very good resistance to aggressive, oxidizing and reducing atmospheres, even at high temperatures ■ Resistant to corrosion caused by chlorine gas and chlorinated media as well as many oxidizing mineral and organic acids, sea water etc. ■ Corrosion from ultrapure water ■ Not to be used in a sulfur-containing atmosphere

1) Can be used to a limited extent up to 800 °C (1472 °F) for low compressive loads and in non-corrosive media. Please contact your Endress+Hauser sales team for further information.

Components

Family of temperature transmitters

Thermometers fitted with iTEMP transmitters are an installation-ready complete solution to improve temperature measurement by significantly increasing accuracy and reliability, when compared to direct wired sensors, as well as reducing both wiring and maintenance costs.

PC programmable head transmitters

They offer a high degree of flexibility, thereby supporting universal application with low inventory storage. The iTEMP transmitters can be configured quickly and easily at a PC. Endress+Hauser offers free configuration software which can be downloaded from the Endress+Hauser Website. More information can be found in the Technical Information.

HART® programmable head transmitters

The transmitter is a 2-wire device with one or two measuring inputs and one analog output. The device not only transfers converted signals from resistance thermometers and thermocouples, it also transfers resistance and voltage signals using HART® communication. It can be installed as an intrinsically safe apparatus in Zone 1 hazardous areas and is used for instrumentation in the terminal head (flat face) as per DIN EN 50446. Swift and easy operation, visualization and maintenance using universal device configuration tools like FieldCare, DeviceCare or FieldCommunicator 375/475. For more information, see the Technical Information.

PROFIBUS® PA head transmitters

Universally programmable head transmitter with PROFIBUS® PA communication. Conversion of various input signals into digital output signals. High accuracy over the complete ambient temperature range. The configuration of PROFIBUS PA functions and of device-specific parameters is performed via fieldbus communication. For more information, see the Technical Information.

FOUNDATION Fieldbus™ head transmitters

Universally programmable head transmitter with FOUNDATION Fieldbus™ communication. Conversion of various input signals into digital output signals. High accuracy over the complete ambient temperature range. All transmitters are released for use in all important process control systems. The integration tests are performed in Endress+Hauser's "System World". For more information, see the Technical Information.

Advantages of the iTEMP transmitters:

- Dual or single sensor input (optionally for certain transmitters)
- Pluggable display (optionally for certain transmitters)
- Unsurpassed reliability, accuracy and long-term stability in critical processes
- Mathematical functions
- Monitoring of the thermometer drift, sensor backup functionality, sensor diagnostic functions
- Sensor-transmitter matching for dual sensor input transmitters, based on Callendar/Van Dusen coefficients

Terminal heads

All terminal heads have an internal shape and size in accordance with DIN EN 50446 flat face and a thermometer connection of M24x1.5, G1/2" or 1/2" NPT thread. All dimensions in mm (in). The cable glands in the diagrams correspond to M20x1.5 connections. Specifications without head transmitter installed. For ambient temperatures with head transmitter installed, see "Operating conditions" section.

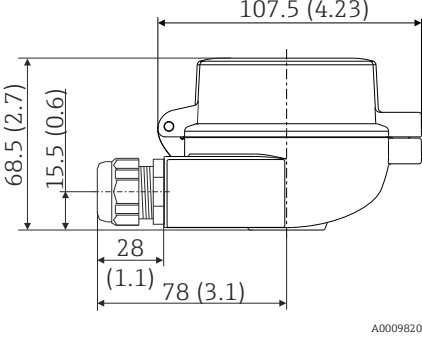
TA30A	Specification
	<ul style="list-style-type: none"> ■ Degree of protection: <ul style="list-style-type: none"> - IP66/68 (NEMA Type 4x incl.) - For ATEX: IP66/67 ■ Temperature: -50 to +150 °C (-58 to +302 °F) without cable gland ■ Material: aluminum, polyester powder coated ■ Seals: silicone ■ Cable entry thread: G ½", ½" NPT and M20x1.5; ■ Protective fitting connection: M24x1.5 ■ Color of head: blue, RAL 5012 ■ Color of cap: gray, RAL 7035 ■ Weight: 330 g (11.64 oz) ■ Ground terminal, internal and external ■ 3-A marked

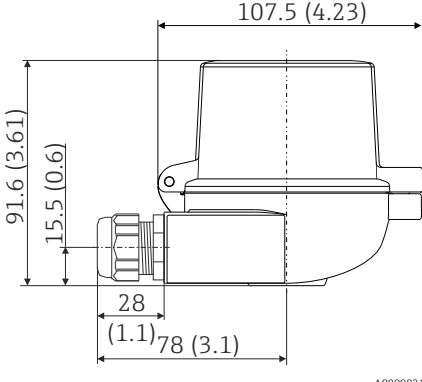
TA30A with display window in cover	Specification
	<ul style="list-style-type: none"> ■ Degree of protection: <ul style="list-style-type: none"> - IP66/68 (NEMA Type 4x incl.) - For ATEX: IP66/67 ■ Temperature: -50 to +150 °C (-58 to +302 °F) without cable gland ■ Material: aluminum, polyester powder coated ■ Seals: silicone ■ Cable entry thread: G ½", ½" NPT and M20x1.5 ■ Protective fitting connection: M24x1.5 ■ Color of head: blue, RAL 5012 ■ Color of cap: gray, RAL 7035 ■ Weight: 420 g (14.81 oz) ■ With TID10 display ■ Ground terminal, internal and external ■ 3-A marked

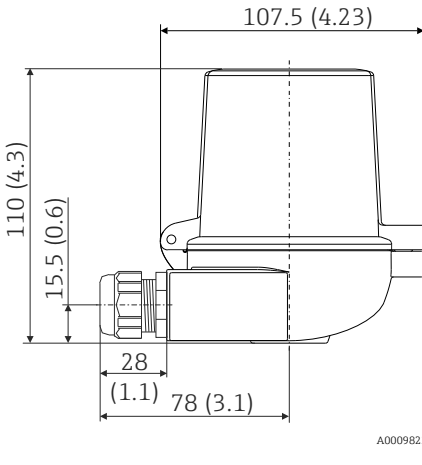
TA30D	Specification
	<ul style="list-style-type: none"> ■ Degree of protection: <ul style="list-style-type: none"> - IP66/68 (NEMA Type 4x incl.) - For ATEX: IP66/67 ■ Temperature: -50 to +150 °C (-58 to +302 °F) without cable gland ■ Material: aluminum, polyester powder coated ■ Seals: silicone ■ Cable entry thread: G ½", ½" NPT and M20x1.5 ■ Protective fitting connection: M24x1.5 ■ Two head transmitters can be mounted. In the standard configuration one transmitter is mounted in the terminal head cover and an additional terminal block is installed directly on the insert. ■ Color of head: blue, RAL 5012 ■ Color of cap: gray, RAL 7035 ■ Weight: 390 g (13.75 oz) ■ Ground terminal, internal and external ■ 3-A marked

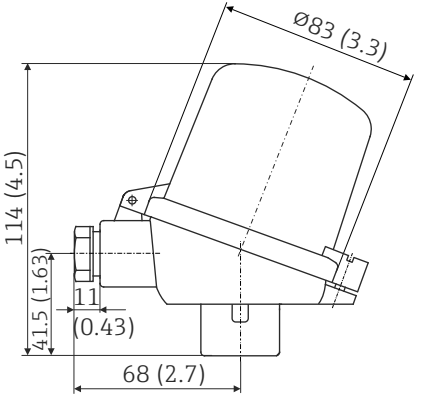
TA30P	Specification
 <p style="text-align: right; font-size: small;">A0012930</p>	<ul style="list-style-type: none"> ■ Protection class: IP65 ■ Max. temperature: -40 to +120 °C (-40 to +248 °F) ■ Material: polyamide (PA), antistatic ■ Seals: silicone ■ Threaded cable entry: M20x1.5 ■ Protection armature connection: M24x1.5 ■ Two head transmitters can be mounted. In the standard version, one transmitter is mounted in the terminal head cover and an additional terminal block is installed directly on the insert. ■ Head and cap color: black ■ Weight: 135 g (4.8 oz) ■ Types of protection for use in hazardous locations: Intrinsic Safety (G Ex ia) ■ Ground terminal: only internal via auxiliary clamp

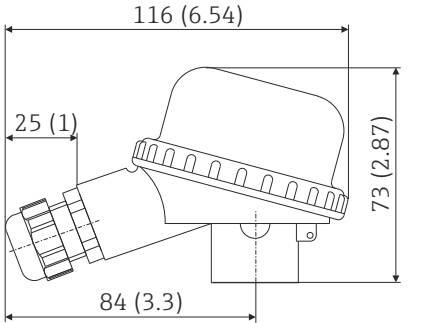
TA20B	Specification
 <p style="text-align: right; font-size: small;">A0008663</p>	<ul style="list-style-type: none"> ■ Protection class: IP65 ■ Max. temperature: -40 to +80 °C (-40 to +176 °F) without cable gland ■ Material: polyamide (PA) ■ Cable entry: M20x1.5 ■ Head and cap color: black ■ Weight: 80 g (2.82 oz) ■ 3-A[®] marked

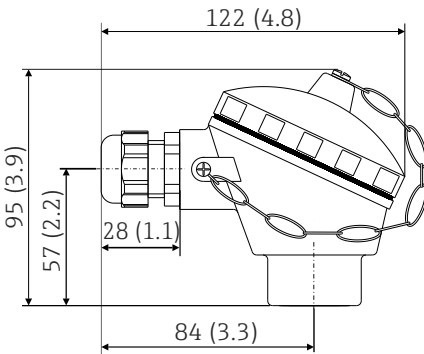
TA21E	Specification
 <p style="text-align: right; font-size: small;">A0008669</p>	<ul style="list-style-type: none"> ■ Protection class: IP65 (NEMA Type 4x encl.) ■ Temperature: -40 to 130 °C (-40 to 266 °F) silicone, up to 100 °C (212 °F) rubber seal without cable gland (observe max. permitted temperature of the cable gland!) ■ Material: aluminum alloy with polyester or epoxy coating, rubber or silicone seal under the cover ■ Cable entry: M20x1.5 or plug M12x1 PA ■ Protection armature connection: M24x1.5, G 1/2" or NPT 1/2" ■ Head color: blue, RAL 5012 ■ Cap color: gray, RAL 7035 ■ Weight: 300 g (10.58 oz) ■ 3-A[®] marked

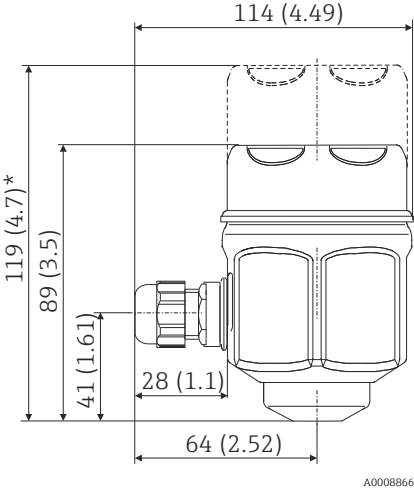
TA20J	Specification
 <p>* dimensions with optional display</p>	<ul style="list-style-type: none"> ▪ Protection class: IP66/IP67 (NEMA Type 4x encl.) ▪ Temperature: -40 to 70 °C (-40 to 158 °F) without cable gland ▪ Material: 316L (1.4404) stainless steel, rubber seal under the cover (hygienic design) ▪ 4 digits 7-segments LC display (loop powered with optional 4 to 20 mA transmitter) ▪ Cable entry: 1/2" NPT, M20x1.5 or plug M12x1 PA ▪ Protection armature connection: M24x1.5 or 1/2" NPT ▪ Head and cap color: stainless steel, polished ▪ Weight: 650 g (22.93 oz) with display ▪ Humidity: 25 to 95 %, no condensation ▪ 3-A[®] marked <p>The programming is executed through 3 keys at the bottom of the display.</p>

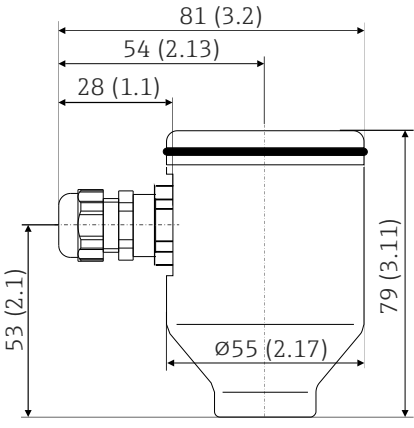
TA20R	Specification
	<ul style="list-style-type: none"> ▪ Protection class: IP66/67 ▪ Max. temperature: -40 to +100 °C (-40 to +212 °F) without cable gland ▪ Material: SS 316L (1.4404) stainless steel ▪ Cable entry: 1/2" NPT, M20x1.5 or plug M12x1 PA ▪ Head and cap color: stainless steel ▪ Weight: 550 g (19.4 oz) ▪ LABS-free ▪ 3-A[®] marked

Maximum ambient temperatures for cable glands and fieldbus connectors	
Type	Temperature range
Cable gland 1/2" NPT, M20x1.5 (non Ex)	-40 to +100 °C (-40 to +212 °F)
Cable gland M20x1.5 (for dust ignition-proof area)	-20 to +95 °C (-4 to +203 °F)
Fieldbus connector (M12x1 PA, 7/8" FF)	-40 to +105 °C (-40 to +221 °F)

Design

All dimensions in mm (in).

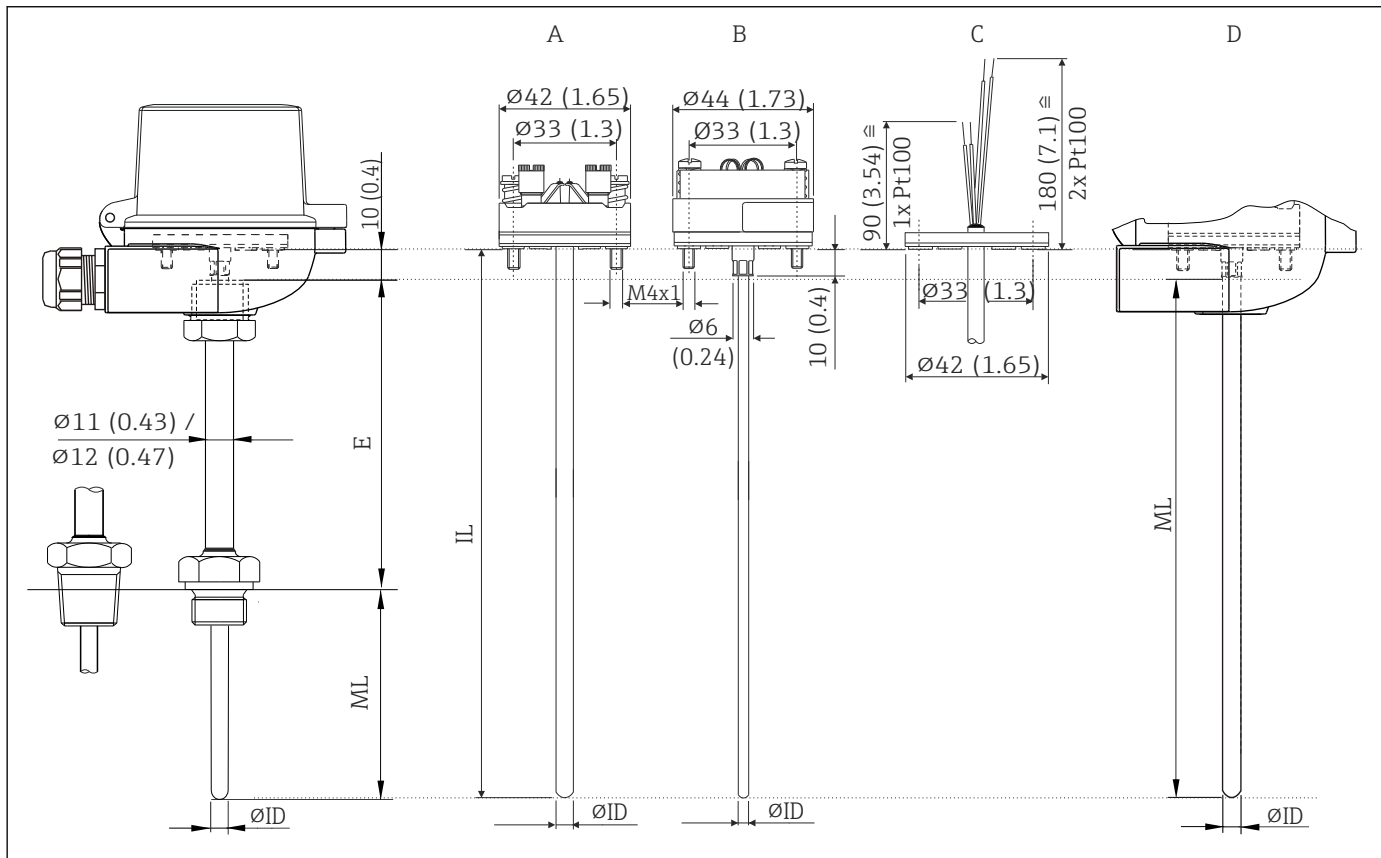

A0012662

3 Dimensions of the Omnigrad S TR88 and TC88

- A Insert with terminal block mounted
- B Insert with head transmitter mounted
- C Insert with flying leads
- D Model without extension neck, intended for mounting in an existing onsite extension neck
- E Extension neck length
- IL Total length of insert
- ML Insertion length
- ØID Insert diameter

i The insertion length (ML) must be selected on the basis of the total length and the **type of thermowell used**.

Insert Depending on the application different inserts are available for the assembly:

Sensor	Standard thin-film	iTHERM StrongSens	Wire wound	
Sensor design; connection method	1x Pt100, 3- or 4-wire, mineral insulated	1x Pt100, 3- or 4-wire, mineral insulated	1x Pt100, 3- or 4-wire, mineral insulated	2x Pt100, 3-wire, mineral insulated
Vibration resistance of the insert tip	Up to 3g	Enhanced vibration resistance > 60g	Up to 3g	
Measuring range; accuracy class	-50 to +400 °C (-58 to +752 °F), Class A or AA	-50 to +500 °C (-58 to +932 °F), Class A or AA	-200 to +600 °C (-328 to +1112 °F), Class A or AA	
Diameter	3 mm (1/8 in), 6 mm (1/4 in)	6 mm (1/4 in)	3 mm (1/8 in), 6 mm (1/4 in)	
Insert type	TPR100	iTHERM TS111	TPR100	

TC				
Selection in order code	A	B	E	F
Sensor design; material	1x K; Alloy 600	2x K; Alloy 600	1x J; 316L	2x J; 316L
Measuring range acc. to:				
DIN EN 60584	-40 to 1200 °C		-40 to 750 °C	
ANSI MC 96.1	0 to 1250 °C		0 to 750 °C	
TC Standard, accuracy	IEC 60584-2; class 1 ASTM E230-03; special			
Insert type	TPC100			
Diameter	ø3 mm (0.12 in) or ø6 mm (0.24 in), depending on the selected tip shape			

Weight 0.5 to 2.5 kg (1 to 5.5 lbs) for standard options.

Process connection

The thermometer is designed for installation in an existing onsite thermowell or in a thermowell which can be ordered separately. The installation is done using the threaded connection on the bottom of the extension neck or using a compression fitting.

Threaded connection		Version		Thread length TL	Width across flats AF
Cylindrical	Conical	M	M14x1.5	12 mm (0.47 in)	17
			M18x1.5		24
			M20x1.5	15 mm (0.6 in)	24
		G	G 1/2"	15 mm (0.6 in)	27
		NPT	NPT 1/2"	8 mm (0.32 in)	22
		R	R 3/4"	8.5 mm (0.33 in)	27
R 1/2"	22				

Threaded compression fitting (TA50)	F	L	B	Clamping ring material	Max. process temperature	Max. process pressure
	G1/2"	47 mm (1.85 in)	15 mm (0.6 in)	SS316 ¹⁾	500 °C (932 °F)	40 bar at 20 °C (580 psi at 68 °F)

1) SS316 compression ferrule: Can only be used once, the compression fitting cannot be repositioned on the protection tube after loosening. Fully adjustable immersion length on initial installation.

i When using a compression fitting the thermometer is pushed through a gland and fixed using a metal ferrule (cannot be loosened).

Spare parts

- The RTD insert is available as spare part TPR100 → 22
- Der iTHERM StrongSens is available as spare part TS111 → 22
- The TC insert is available as spare part TPC100 → 22

The inserts are made from mineral insulated cable (MgO) with a sheath in AISI316L/1.4404 (RTD) or Alloy 600 (TC).

If spare parts are required, refer to the following equation:

Insertion length IL = E + L + 10 mm (0.4 in)

- Extension neck welded with threaded connection to terminal head. DIN flat face, different connections to separate thermowell, **order number TN15-...**
- Compression fitting with thread, ϕ 12 mm (0.47 in), process connection thread G1/2", clamping ring made of 316L stainless steel, **order number TA50-KC**

Wiring

Wiring diagrams for RTD

Type of sensor connection

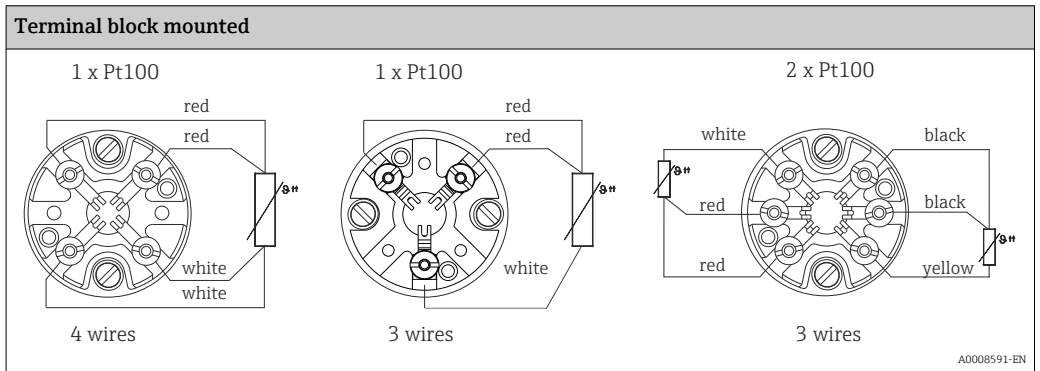
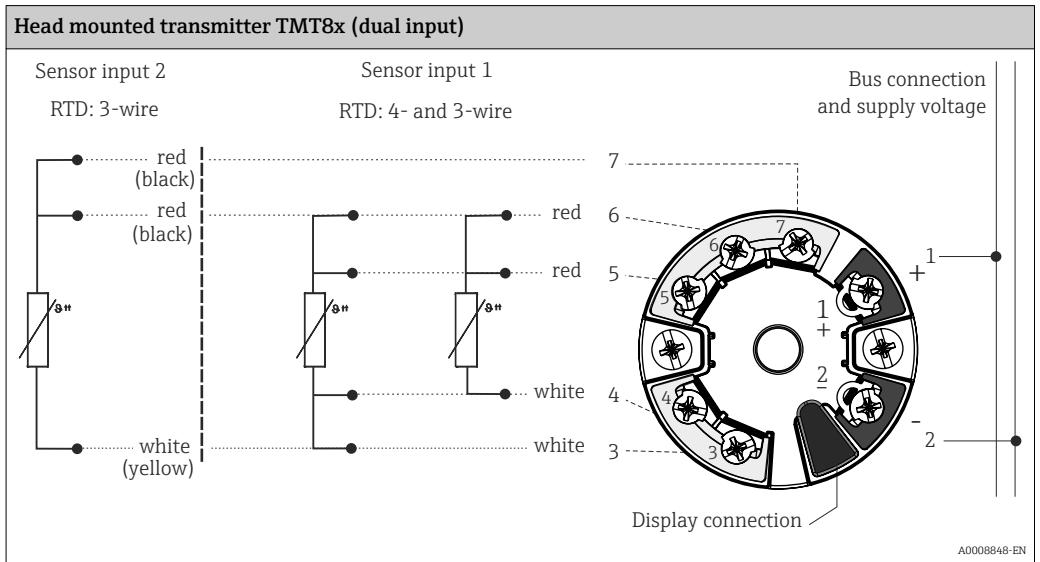
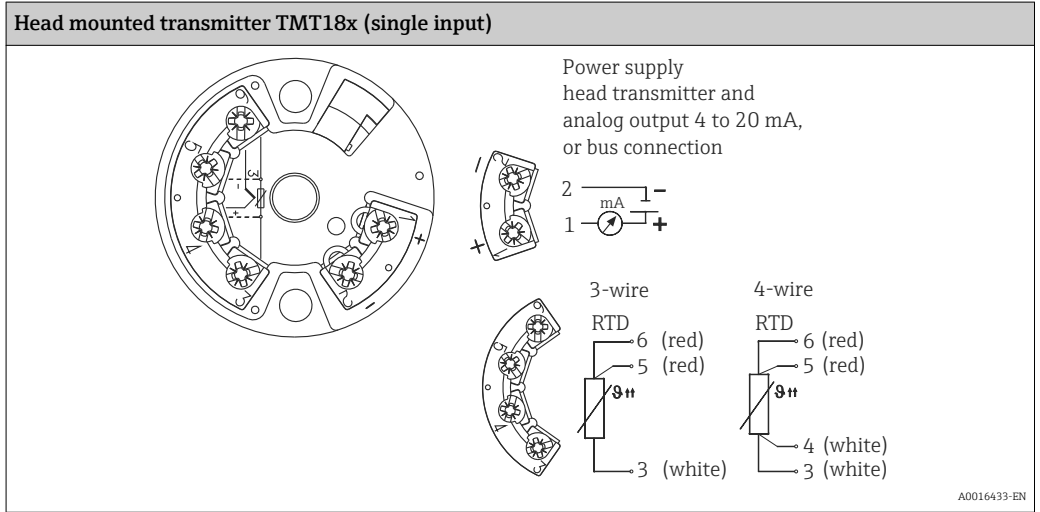

Wiring diagrams for TC

Thermocouple wire colors

As per IEC 60584	As per ASTM E230
<ul style="list-style-type: none"> Type J: black (+), white (-) Type K: green (+), white (-) 	<ul style="list-style-type: none"> Type J: white (+), red (-) Type K: yellow (+), red (-)

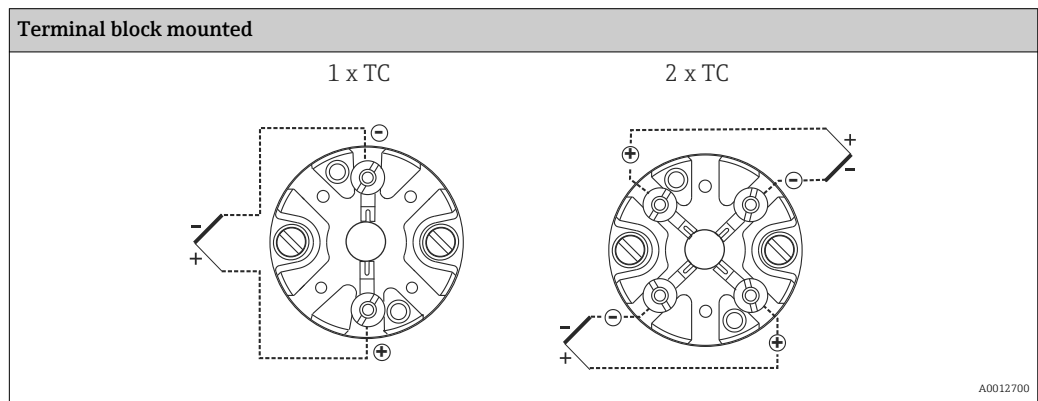
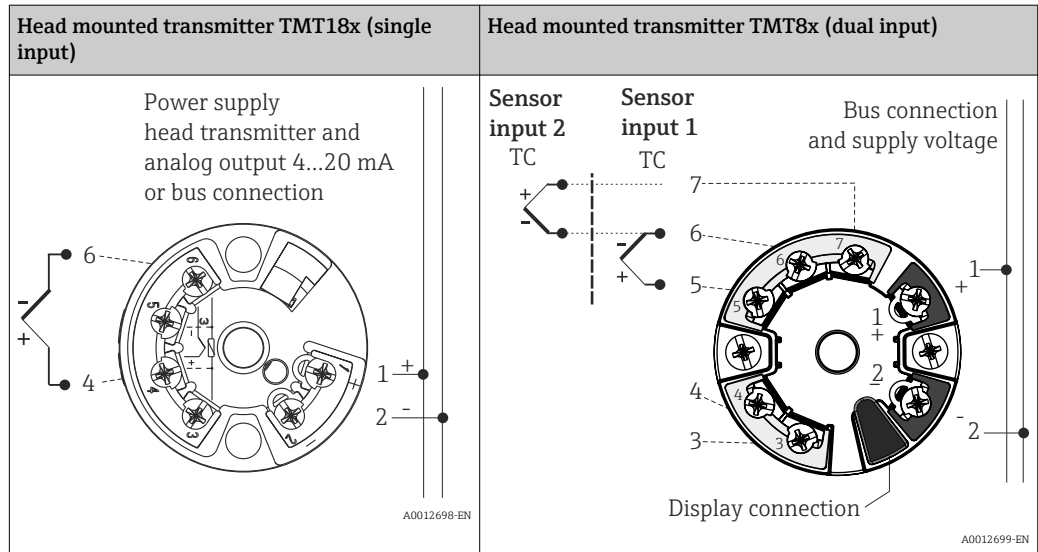

Installation conditions

Orientation No restrictions.

Installation constructions

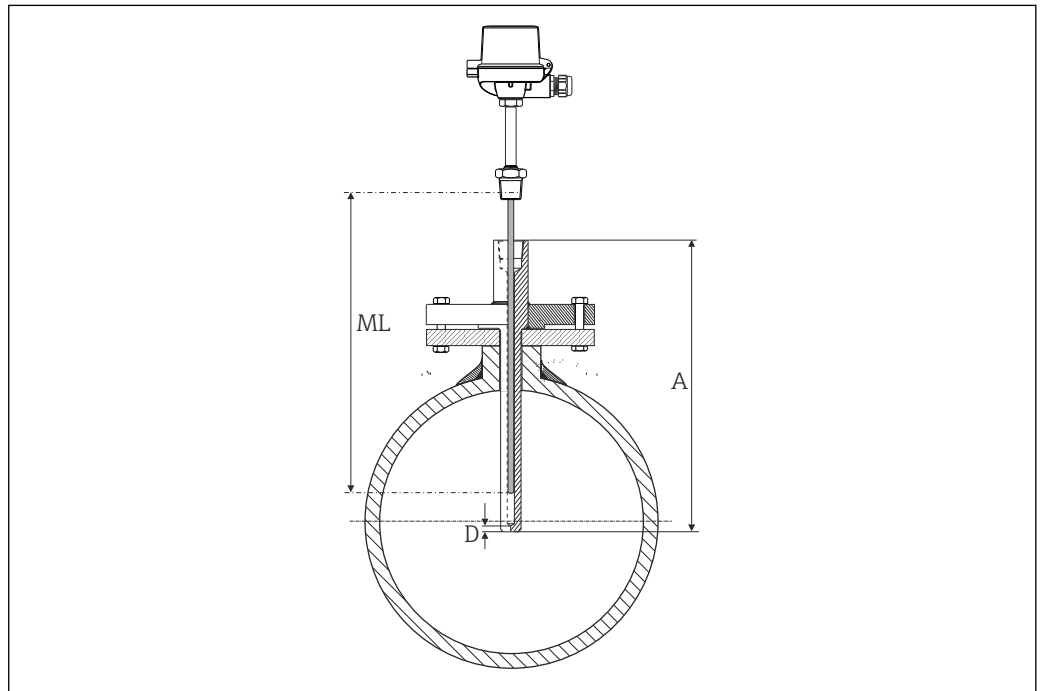

4 Thermometer installation

The thermometer is designed for installation in an existing thermowell or in a thermowell which can be ordered separately. Different threaded connections to suit the thermowell are available on the thermometer's extension neck (*Verweiszijel bestaat niet, maar @y.link.required=true*). The necessary insertion length (ML) of the insert depends on the total length of the thermowell (A) and the type of thermowell used. It can be freely selected within the range of 100 to 5 000 mm (3.94 to 197 in). Longer insertion lengths are available on request. This also applies when ordering the insert as a spare part. More detailed information on determining the insertion length (ML) required in each case can be found in the following table (applies to Endress +Hauser thermowells with standard base thicknesses (D)).

Type of thermowell	ML in mm (in)	Type of thermowell	ML in mm (in)
TA535	ML = A	TA565	ML = A - 3 (0.12)
TA540 (flat tip)	ML = A - 2 (0.08)	TA566	ML = A - 3 (0.12)
TA540 (round tip)	ML = A - 7 (0.28)	TA570	ML = A - 3 (0.12)
TA550	ML = A - 3 (0.12)	TA571	ML = A - 3 (0.12)
TA555	ML = A - 2 (0.08)	TA572	ML = A - 3 (0.12)
TA557	ML = A - 2 (0.08)	TA575	ML = A - 3 (0.12)
TW15	ML = A	TA576	ML = A - 2 (0.08)
TA560	ML = A - 3 (0.12)		
TA562	ML = A - 3 (0.12)		

In the case of thermowells with a noncompliant standard base thickness (D), the following formula must be used: **ML = A - D + 3 (0.12)** in mm (in).

Extension neck length

The extension neck is the part between the process connection and the terminal head. As illustrated in the following diagram, the extension neck length influences the temperature in the terminal head. This temperature must remain within the limit values defined in the "Operating conditions" section.

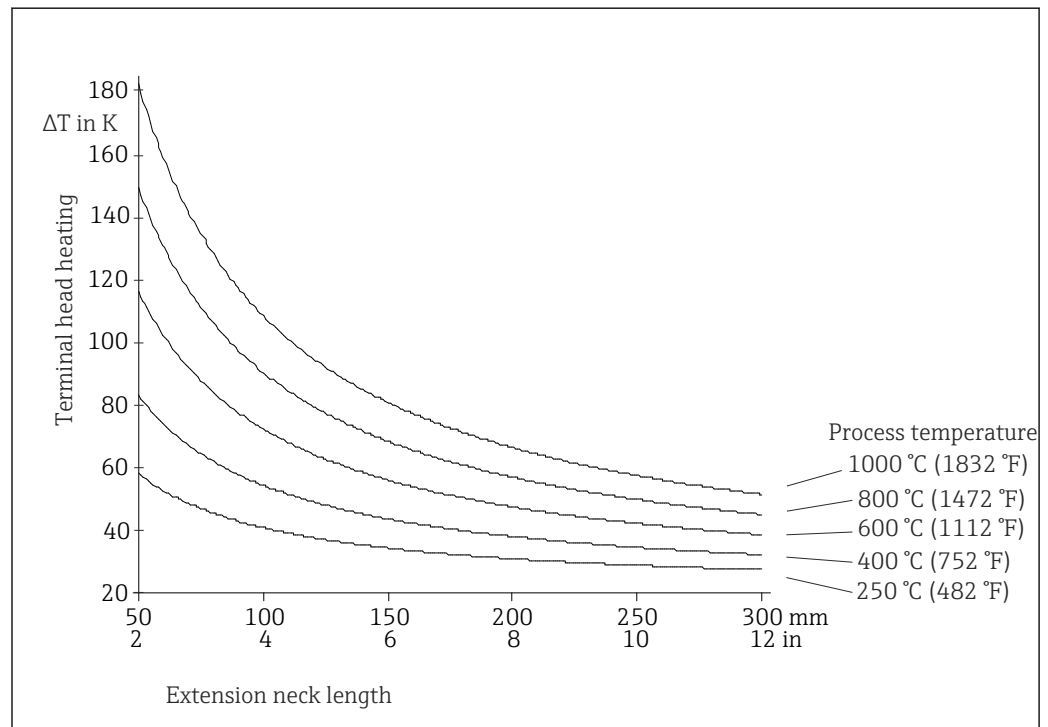

5 Heating of the terminal head as a function of the process temperature. Temperature in terminal head = ambient temperature 20 °C (68 °F) + ΔT

Certificates and approvals

CE mark The measuring system meets the legal requirements of the applicable EC guidelines. These are listed in the corresponding EC Declaration of Conformity together with the standards applied. The manufacturer confirms successful testing of the device by affixing to it the CE mark.

Hazardous area approvals For further details on the available Ex versions (ATEX, CSA, FM etc.), please contact your nearest Endress+Hauser sales organization. All relevant data for hazardous areas can be found in separate Ex documentation.

Other standards and guidelines

- IEC 60529: Degrees of protection provided by enclosures (IP code)
- IEC/EN 61010-1: Safety requirements for electrical equipment for measurement, control and laboratory use
- IEC 60751: Industrial platinum resistance thermometers
- IEC 60584 and ASTM E230/ANSI MC96.1: Thermocouples
- DIN EN 50446: Terminal heads

Test report and calibration The "Factory calibration" is carried out according to an internal procedure in a laboratory of Endress+Hauser accredited by the European Accreditation Organization (EA) to ISO/IEC 17025. A calibration which is performed according to EA guidelines (SIT/Accredia) or (DKD/DAKKS) may be requested separately. The calibration is performed on the replaceable insert of the thermometer. In the case of thermometers without a replaceable insert, the entire thermometer - from the process connection to the tip of the thermometer - is calibrated.

Ordering information

Detailed ordering information is available from the following sources:

- In the Product Configurator on the Endress+Hauser website: www.endress.com -> Click "Corporate" -> Select your country -> Click "Products" -> Select the product using the filters and search field -> Open product page -> The "Configure" button to the right of the product image opens the Product Configurator.
- From your Endress+Hauser Sales Center: www.addresses.endress.com









Product Configurator - the tool for individual product configuration

- Up-to-the-minute configuration data
- Depending on the device: Direct input of measuring point-specific information such as measuring range or operating language
- Automatic verification of exclusion criteria
- Automatic creation of the order code and its breakdown in PDF or Excel output format
- Ability to order directly in the Endress+Hauser Online Shop

Accessories

Various accessories, which can be ordered with the device or subsequently from Endress+Hauser, are available for the device. Detailed information on the order code in question is available from your local Endress+Hauser sales center or on the product page of the Endress+Hauser website: www.endress.com.

Communication-specific accessories



Configuration kit TXU10	Configuration kit for PC-programmable transmitter with setup software and interface cable for PC with USB port Order code: TXU10-xx
Commubox FXA195 HART	For intrinsically safe HART communication with FieldCare via the USB interface.  For details, see "Technical Information" TI00404F
Commubox FXA291	Connects Endress+Hauser field devices with a CDI interface (= Endress+Hauser Common Data Interface) and the USB port of a computer or laptop.  For details, see "Technical Information" TI00405C
HART Loop Converter HMX50	Is used to evaluate and convert dynamic HART process variables to analog current signals or limit values.  For details, see "Technical Information" TI00429F and Operating Instructions BA00371F
Wireless HART adapter SWA70	Is used for the wireless connection of field devices. The WirelessHART adapter can be easily integrated into field devices and existing infrastructures, offers data protection and transmission safety and can be operated in parallel with other wireless networks with minimum cabling complexity.  For details, see Operating Instructions BA061S
Fieldgate FXA320	Gateway for the remote monitoring of connected 4-20 mA measuring devices via a Web browser.  For details, see "Technical Information" TI00025S and Operating Instructions BA00053S
Fieldgate FXA520	Gateway for the remote diagnostics and remote configuration of connected HART measuring devices via a Web browser.  For details, see "Technical Information" TI00025S and Operating Instructions BA00051S
Field Xpert SFX100	Compact, flexible and robust industry handheld terminal for remote configuration and for obtaining measured values via the HART current output (4-20 mA).  For details, see Operating Instructions BA00060S

Service-specific accessories

Accessories	Description
Applicator	Software for selecting and sizing Endress+Hauser measuring devices: <ul style="list-style-type: none"> Calculation of all the necessary data for identifying the optimum measuring device: e.g. pressure loss, accuracy or process connections. Graphic illustration of the calculation results Administration, documentation and access to all project-related data and parameters over the entire life cycle of a project. Applicator is available: Via the Internet: https://portal.endress.com/webapp/applicator

Configurator	<p>Product Configurator - the tool for individual product configuration</p> <ul style="list-style-type: none"> ▪ Up-to-the-minute configuration data ▪ Depending on the device: Direct input of measuring point-specific information such as measuring range or operating language ▪ Automatic verification of exclusion criteria ▪ Automatic creation of the order code and its breakdown in PDF or Excel output format ▪ Ability to order directly in the Endress+Hauser Online Shop <p>The Configurator is available on the Endress+Hauser website: www.endress.com -> Click "Corporate" -> Select country -> Click "Products" -> Select the product using the filters and search field -> Open product page -> The "Configure" button to the right of the product image opens the Product Configurator.</p>
W@M	<p>Life cycle management for your plant</p> <p>W@M supports with a wide range of software applications over the entire process: from planning and procurement, to the installation, commissioning and operation of the measuring devices. All the relevant device information, such as the device status, spare parts and device-specific documentation, is available for every device over the entire life cycle.</p> <p>The application already contains the data of your Endress+Hauser device. Endress+Hauser also takes care of maintaining and updating the data records.</p> <p>W@M is available: Via the Internet: www.endress.com/lifecyclemanagement</p>

System components

Accessories	Description
Field display unit RIA16	<p>The display unit records the analog measuring signal from the head transmitter and shows this on the display. The LC display shows the current measured value in digital form and as a bar graph indicating a limit value violation. The display unit is looped into the 4 to 20 mA circuit and gets the required energy from there.</p> <p> For details, see the "Technical Information" document TI00144R/09/en</p>
RN221N	<p>Active barrier with power supply for safe separation of 4-20 mA standard signal circuits. Offers bidirectional HART transmission.</p> <p> For details, see "Technical Information" TI00073R and Operating Instructions BA00202R</p>
RNS221	<p>Supply unit for powering two 2-wire measuring devices solely in the non-Ex area. Bidirectional communication is possible via the HART communication jacks.</p> <p> For details, see "Technical Information" TI00081R and Brief Operating Instructions KA00110R</p>

Documentation

Technical Information:

- iTEMP Temperature head transmitter:
 - TMT180, PC-programmable, single-channel, Pt100 (TI088R/09/en)
 - PCP TMT181, PC-programmable, single-channel, RTD, TC, Ω , mV (TI00070R/09/en)
 - HART[®] TMT182, single-channel, RTD, TC, Ω , mV (TI078R/09/en)
 - HART[®] TMT82, two-channel, RTD, TC, Ω , mV (TI01010T/09/en)
 - PROFIBUS[®] PA TMT84, two-channel, RTD, TC, Ω , mV (TI138R/09/en)
 - FOUNDATION Fieldbus[™] TMT85, two-channel, RTD, TC, Ω , mV (TI134R/09/en)
- Inserts:
 - Resistance thermometer insert Omniset TPR100 (TI268t/02/en)
 - Thermocouple insert Omniset TPC100 (TI278t/02/en)
 - iTHERM TS111 Insert for installation in thermometers (TI01014T/09/en)
- Application example:
 - RN221N Active barrier, for supplying loop-powered transmitters (TI073R/09/en)
 - RIA16 Field display unit, loop-powered (TI00144R/09/en)

Technical information thermowells:

Type of thermowell			
TA535	TI250T/02/en	TA565	TI160T/02/en
TA540	TI00166T/09/en	TA566	TI177T/02/en
TA550	TI153T/02/en	TA570	TI161T/02/en
TA555	TI154T/02/en	TA571	TI178T/02/en
TA557	TI156T/02/en	TA572	TI179T/02/en
TW15	TI00265T/02/en	TA575	TI162T/02/en
TA560	TI159T/02/en	TA576	TI163T/02/en
TA562	TI00230T/09/en		

Supplementary ATEX documentation:

- Omnigrad TRxx, TCxx, TSTxxx, TxCxxx; Omniset TPR100, TET10x, TPC100, TEC10x, iTHERM TS111 ATEX II 3GD Ex nA (XA00044R/09/a3)
- RTD/TC Thermometer Omnigrad TRxx, TCxx, TxCxxx, ATEX II 1GD or II 1/2GD Ex ia IIC T6...T1 (XA00072R/09/a3)
- Inserts Omniset TPR100, TPC100, ATEX II 1G (XA087R/09/a3)
- iTHERM TS111, TM211 Omnigrad TST310, TSC310 Omniset TPR100, TPC100 IECEx Ex ia IIC T6...T1 (XA00100R/09/a3)

www.addresses.endress.com
