

Technical Information

Flowfit CUA262

Flow assembly for CUS52D turbidity sensor



Application

The CUA262 flow assembly is designed for the installation of the CUS52D turbidity sensor. The assembly enables the installation of the sensor directly in the flow of process water. It can be inserted as a weld-in element in stainless steel pipe networks.

Its main areas of application are:

- Turbidity measurement at all stages of the process in skids for water treatment
- Turbidity measurement in closed piping systems (stainless steel)
- Turbidity check in filter modules

Your benefits

- Direct installation in the process
- No lost water, no product discarded
- Self-venting thanks to vertical installation
- Stainless steel material ensures suitability for use in drinking water

Function and system design

Measuring arrangement

A complete measuring system consists of:

- Flowfit CUA262 flow assembly
- Turbimax CUS52D sensor
- Transmitter, e.g. Liquiline CM442
- Measuring cable

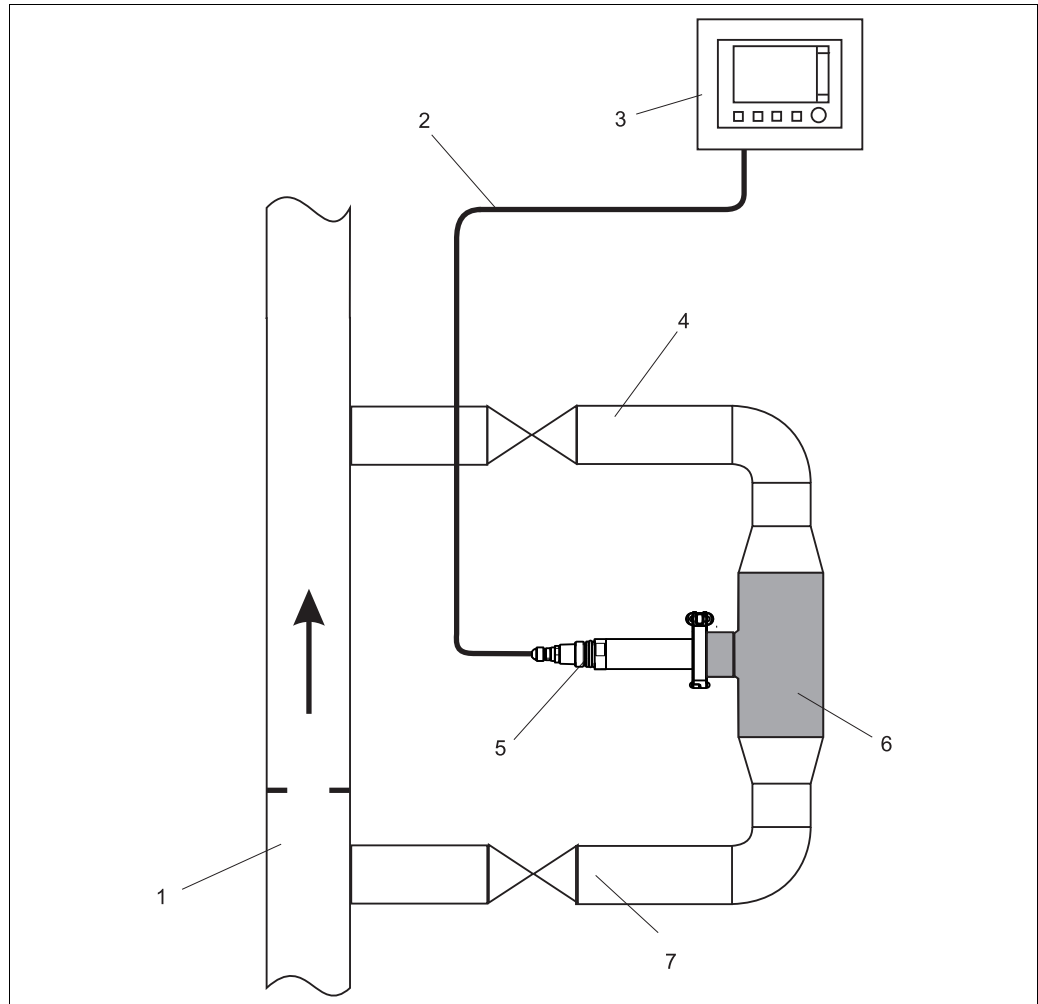

a0022868

Measuring system (example)

- | | |
|---|--------------------------------|
| 1 | Process pipe |
| 2 | Measuring cable |
| 3 | Liquiline CM442 transmitter |
| 4 | Return line with shutoff valve |
| 5 | CUS52D sensor |
| 6 | Flowfit CUA262 flow assembly |
| 7 | Supply line with shutoff valve |

Installation

Installation instructions

Installation in the process pipe

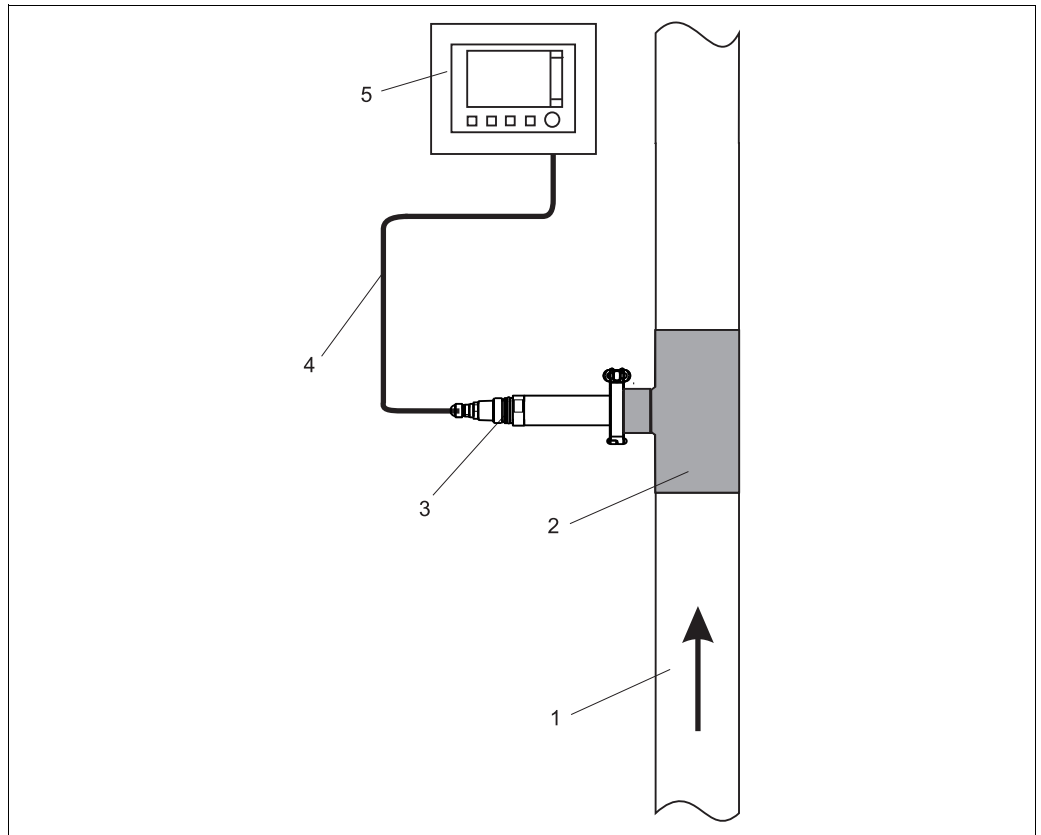

a0022898

Installation in the process pipe

- 1 Flow direction
- 2 Flowfit CUA262 flow assembly
- 3 CUS52D sensor
- 4 Measuring cable
- 5 Liquiline CM4442 transmitter

Installation in a bypass

To ensure that medium flows through the assembly in a bypass configuration, the pressure p_1 must be greater than the pressure p_2 . This is achieved by installing an orifice plate in the main pipe.

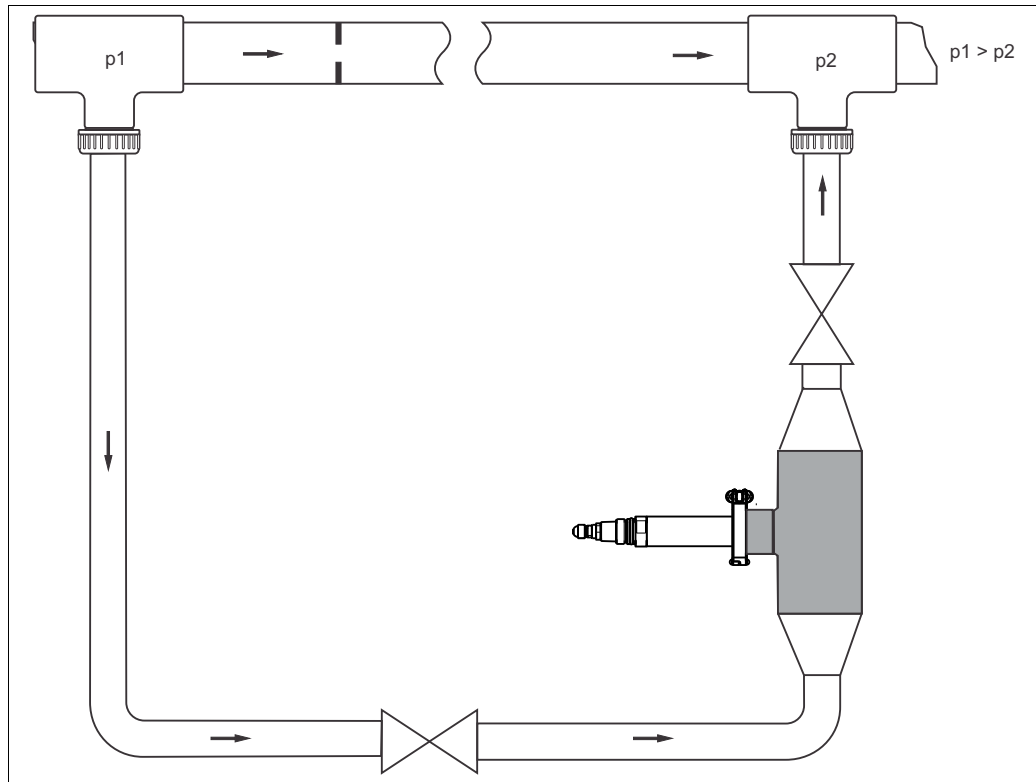

Connection example involving a bypass and an orifice plate in the main pipe (supply from below)

The inlet and outlet connection of the flow assembly are always identical, the system is symmetrical. Install the flow assembly vertically.

The supply must be connected at the bottom (upward flow in the pipe).

 Pay attention to the installation instructions (flow direction) for the sensor.

Wall effects:

Backscattering on the pipe wall may result in the distortion of measurement values in the case of turbidity values < 200 FNU. It is recommended that you adjust the installation.

Black plastic pipes with diameter $> DN 60$ exhibit hardly any wall effects (< 0.05 FNU). For this reason, the use of black plastic pipes is recommended.

Additional information on avoiding wall effects:

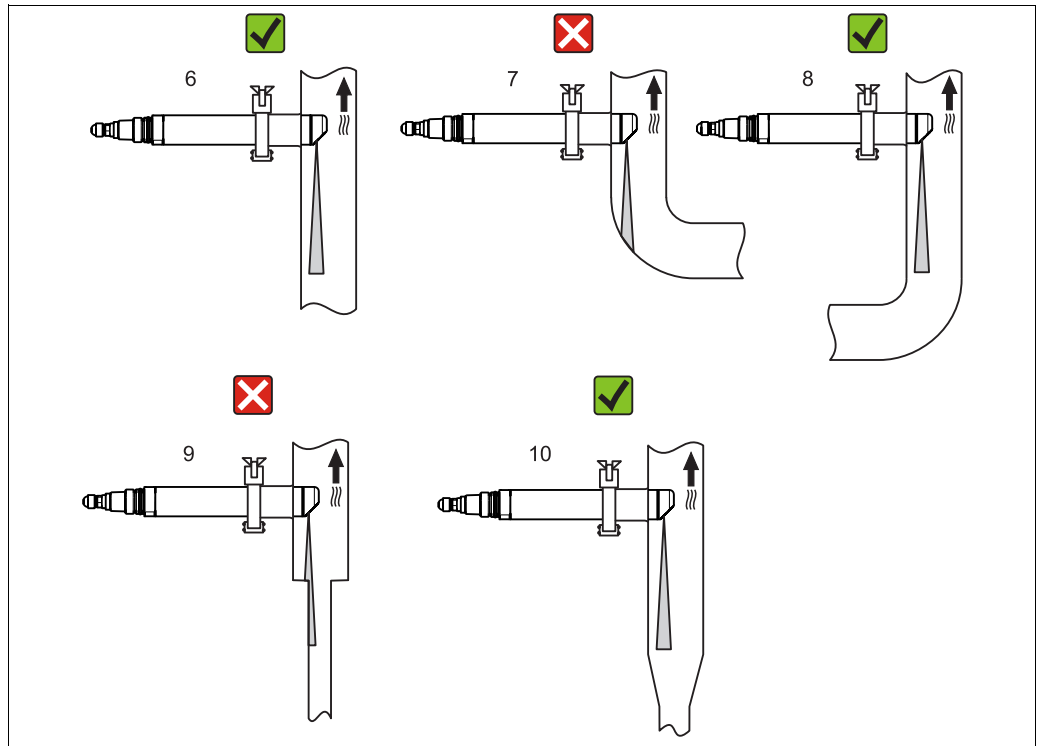

Orientations for pipes and assemblies

- Install the sensor in such a way that the light beam is not reflected (pos. 6).
- Avoid sudden changes in cross-section (pos. 9). Changes in cross-section should be gradual and located as far away as possible from the sensor (pos. 10).
- Do not install the sensor directly downstream from a bend (pos. 7). Instead position it as far away as possible from the bend (pos. 8).
- When using reflective materials (e.g. stainless steel), the pipe diameter must be at least 100 mm (4"). It is recommended that the installation be adjusted on site.
- Pipes made of stainless steel with diameter >DN 300 exhibit hardly any wall effects.

Environment

Ambient temperature range 0 to 55 °C (32 to 131 °F)

Storage temperature 0 to 60 °C (32 to 140 °F) in the original packaging

Process

Process temperature 0 to 85 °C (32 to 185 °F)

Process pressure 0 to 6 bar (0 to 87 psi)

Mechanical construction

Dimensions

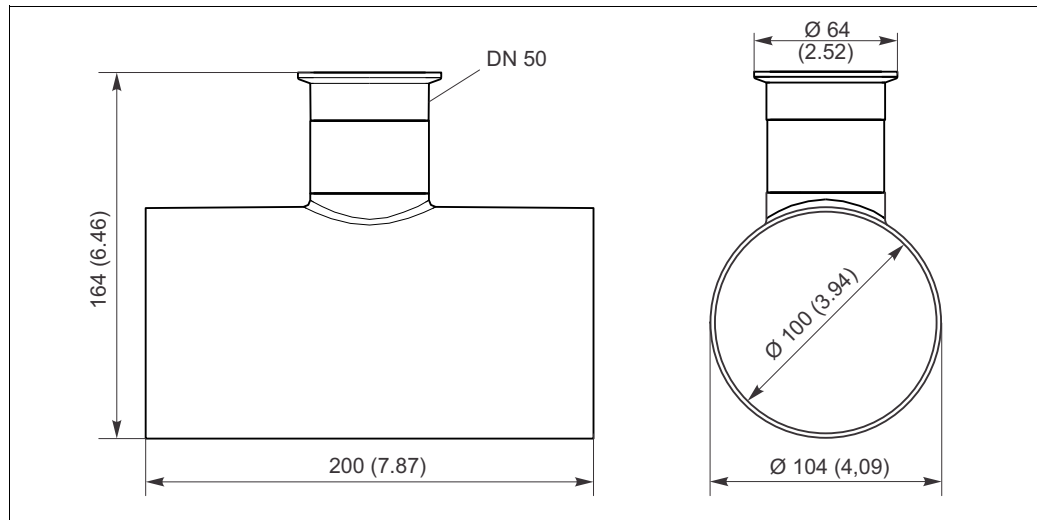

Dimensions in mm (inch)

Weight 1.11 kg (2.45 lbs)

Materials

Assembly housing:	Stainless steel 1.4404 (AISI 316 L)
Seals:	EPDM
Dummy cover:	Stainless steel 1.4404 (AISI 316 L)

Ordering information

Product structure

You can create a valid and complete order code online using the Configurator:
www.products.endress.com/cua262

1. You can choose from the following options on the right of the product page:

Product page function
:: Add to product list
:: Price & order information
:: Compare this product
:: Configure this product

2. Click "Configure this product".
3. The Configurator opens in a separate window. You can now configure your device and you will receive the complete order code valid for that device.
4. Now export the order code as a PDF file or Excel file. To do so, click the appropriate button at the top of the page.

Scope of delivery

- The scope of delivery comprises:
- Flow assembly in the version ordered
 - Operating Instructions, English

Accessories

-  The most important accessories available at the time this document went to print are listed below. Contact your Service Department or sales center for accessories that are not listed here.

Connection accessories

Description	Order number
Dummy cover for clamp connection; 1 pc	71242180

www.addresses.endress.com
