

Operating Instructions

Liquiline Compact CM72

Compact transmitter, preconfigured to sensor parameters for Memosens sensors from the Liquiline series





Table of contents







1	Document information	4	12	Repair	18
1.1	Warnings	4	12.1	General notes	18
1.2	Symbols	4	12.2	Return	18
1.3	Symbols at the device	4	12.3	Disposal	18
1.4	Documentation	5	13	Accessories	19
2	Basic safety instructions	6	13.1	Sensors	19
2.1	Requirements for personnel	6	13.2	Software	22
2.2	Designated use	6	13.3	Other accessories	22
2.3	Occupational safety	6	14	Technical data	24
2.4	Operational safety	6	14.1	Input	24
3	Product description	8	14.2	Output	24
3.1	Product design	8	14.3	Power supply	24
4	Incoming acceptance and product identification	9	14.4	Performance characteristics	25
4.1	Incoming acceptance	9	14.5	Environment	25
4.2	Product identification	9	14.6	Mechanical construction	26
4.3	Scope of delivery	10	Index	28	
4.4	Certificates and approvals	10			
5	Installation	11			
5.1	Dimensions	11			
6	Electrical connection	12			
6.1	Connection	12			
6.2	Post-connection check	13			
7	System integration	14			
7.1	Integrating the measuring device into the system	14			
8	Commissioning	14			
8.1	Preparatory steps	14			
8.2	Function check	14			
9	Operation	15			
9.1	Reading measured values	15			
10	Diagnostics and troubleshooting ...	16			
10.1	Diagnostic information via LED	16			
11	Maintenance	17			
11.1	Maintenance tasks	17			

1 Document information

1.1 Warnings

Structure of information	Meaning
 DANGER Causes (/consequences) If necessary, Consequences of non-compliance (if applicable) <ul style="list-style-type: none"> ▶ Corrective action 	This symbol alerts you to a dangerous situation. Failure to avoid the dangerous situation will result in a fatal or serious injury.
 WARNING Causes (/consequences) If necessary, Consequences of non-compliance (if applicable) <ul style="list-style-type: none"> ▶ Corrective action 	This symbol alerts you to a dangerous situation. Failure to avoid the dangerous situation can result in a fatal or serious injury.
 CAUTION Causes (/consequences) If necessary, Consequences of non-compliance (if applicable) <ul style="list-style-type: none"> ▶ Corrective action 	This symbol alerts you to a dangerous situation. Failure to avoid this situation can result in minor or more serious injuries.
NOTICE Cause/situation If necessary, Consequences of non-compliance (if applicable) <ul style="list-style-type: none"> ▶ Action/note 	This symbol alerts you to situations which may result in damage to property.

1.2 Symbols

Symbol	Meaning
	Additional information, tips
	Permitted or recommended
	Not permitted or not recommended
	Reference to device documentation
	Reference to page
	Reference to graphic
	Result of a step

1.3 Symbols at the device

Symbol	Meaning
	Reference to device documentation

1.4 Documentation

The following instructions complement these Operating Instructions and are available on the product pages on the Internet:

Operating Instructions Memosens, BA01245C

- Software description for Memosens inputs
- Calibration of Memosens sensors
- Sensor-specific diagnostics and troubleshooting

2 Basic safety instructions

2.1 Requirements for personnel

- Installation, commissioning, operation and maintenance of the measuring system may be carried out only by specially trained technical personnel.
- The technical personnel must be authorized by the plant operator to carry out the specified activities.
- The electrical connection may be performed only by an electrical technician.
- The technical personnel must have read and understood these Operating Instructions and must follow the instructions contained therein.
- Faults at the measuring point may only be rectified by authorized and specially trained personnel.

 Repairs not described in the Operating Instructions provided must be carried out only directly at the manufacturer's site or by the service organization.

2.2 Designated use

The Liquiline CM72 is a transmitter for connecting digital sensors with Memosens technology, permanently preset to sensor parameters and measuring range spreading with 4...20mA communication.

The device is designed for use in the following industries:

- Life science
- Chemical industry
- Water and wastewater
- Food and beverages
- Power stations
- Other industrial applications

2.3 Occupational safety

As the user, you are responsible for complying with the following safety conditions:

- Installation guidelines
- Local standards and regulations
- Regulations for explosion protection

Electromagnetic compatibility

- The product has been tested for electromagnetic compatibility in accordance with the applicable European standards for industrial applications.
- The electromagnetic compatibility indicated applies only to a product that has been connected in accordance with these Operating Instructions.

2.4 Operational safety

Before commissioning the entire measuring point:

1. Verify that all connections are correct.
2. Ensure that electrical cables and hose connections are undamaged.
3. Do not operate damaged products, and protect them against unintentional operation.
4. Label damaged products as defective.

During operation:

- ▶ If faults cannot be rectified:
products must be taken out of service and protected against unintentional operation.

 CAUTION**Cleaning not switched off during calibration or maintenance activities**

Risk of injury due to medium or cleaning agent!

- ▶ If a cleaning system is connected, switch it off before removing a sensor from the medium.
- ▶ If you wish to check the cleaning function and have therefore not switched off the cleaning system, wear protective clothing, goggles and gloves or take other appropriate measures.

3 Product description

3.1 Product design

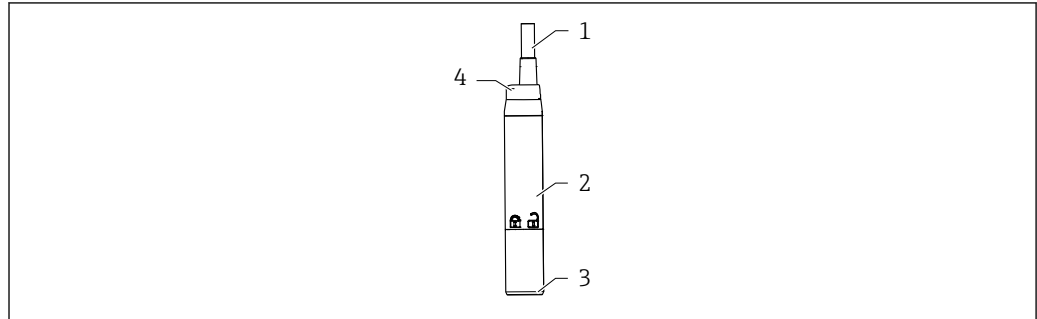

A0036216

1 Transmitter design

- 1 Cable
- 2 Housing
- 3 Memosens connection
- 4 LED, for optical signaling of operating statuses of measuring point

3.1.1 Measuring parameters

The transmitter is designed for digital Memosens sensors with inductive plug-in head:

- pH, ORP. pH/ORP combined sensors
- Conductive Conductivity
- Dissolved oxygen

Depending on the order version, the measuring range is configured to suit the sensor type:

- pH sensor: 0 to 14 pH
- ORP: -1500 mV to +1500 mV
- Conductivity: 0 to 20 $\mu\text{S}/\text{cm}$
- Conductivity: 0 to 500 $\mu\text{S}/\text{cm}$
- Conductivity: 0 to 20 mS/cm
- Conductivity: 0 to 500 mS/cm
- Oxygen: 0 to 200 $\mu\text{g}/\text{l}$
- Oxygen: 0 to 20 mg/l

4 Incoming acceptance and product identification

4.1 Incoming acceptance

1. Verify that the packaging is undamaged.
 - ↳ Notify the supplier of any damage to the packaging.
Keep the damaged packaging until the issue has been resolved.
2. Verify that the contents are undamaged.
 - ↳ Notify the supplier of any damage to the delivery contents.
Keep the damaged goods until the issue has been resolved.
3. Check that the delivery is complete and nothing is missing.
 - ↳ Compare the shipping documents with your order.
4. Pack the product for storage and transportation in such a way that it is protected against impact and moisture.
 - ↳ The original packaging offers the best protection.
Make sure to comply with the permitted ambient conditions.

If you have any questions, please contact your supplier or your local Sales Center.

4.2 Product identification

4.2.1 Nameplate

The nameplate provides you with the following information on your device:

- Manufacturer identification
 - Order code
 - Extended order code
 - Serial number
 - Firmware version
 - Ambient and process conditions
 - Input and output values
 - Safety information and warnings
 - Certificate information
 - Approvals as per version ordered
- ▶ Compare the data on the nameplate with your order.

4.2.2 Product identification

Product page

www.endress.com/CM72

Interpreting the order code

The order code and serial number of your product can be found in the following locations:

- On the nameplate
- In the delivery papers

Obtaining information on the product

1. Open the product website.
2. In the page header, select: **Product tools**.
 - ↳ **Online Tools**: An additional area opens up.

3. Select: **Access device specific information.**
 - ↳ An additional window opens.
4. Enter the order code from the nameplate into the search field. Then select: **Show details.**
 - ↳ Details of each feature (selected option) of the order code are displayed.

4.3 Scope of delivery

The scope of delivery includes:

- CM72
- Brief Operating Instructions
- ▶ If you have any queries:
Please contact your supplier or local sales center.

4.4 Certificates and approvals

4.4.1 CE mark

The product meets the requirements of the harmonized European standards. As such, it complies with the legal specifications of the EU directives. The manufacturer confirms successful testing of the product by affixing to it the **CE** mark.

5 Installation

5.1 Dimensions

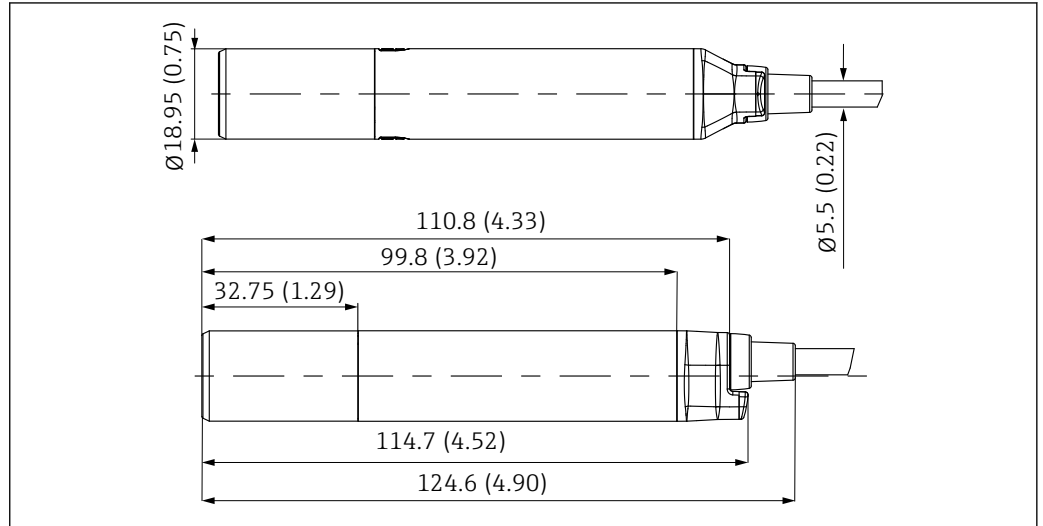

A0033272

2 Dimensions in mm (inch)

6 Electrical connection

⚠ WARNING

Device is live!

Incorrect connection may result in injury or death!

- ▶ The electrical connection may be performed only by an electrical technician.
- ▶ The electrical technician must have read and understood these Operating Instructions and must follow the instructions contained therein.
- ▶ **Prior** to commencing connection work, ensure that no voltage is present on any cable.

6.1 Connection

Supply voltage:	12,6 to 30 VDC (In the case of a residual current > 20 mA) 14 to 30 VDC (When the failure current is set to 3.6 mA.)
Cable length:	3 m (10 ft) 7 m (23 ft) 15 m (46 ft)
Signal output:	4 to 20 mA
Signal on alarm:	3.6 or 23 mA depending on order version

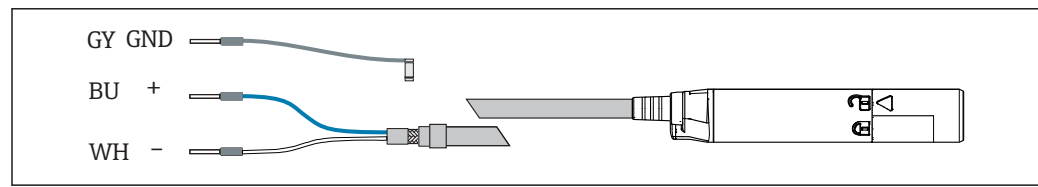

A0033282

3 Electrical connection

- ▶ Connect ferrules as specified in the table:

Cable	Function
Gray (GY)	Grounding, GND
BU (blue)	4 to 20 mA +
White (WH)	4 to 20 mA -

The grounding cable must be provided by the customer.

6.1.1 With RIA15

The RIA15 process display unit is loop-powered and does not require any external power supply.

Further information is available in the RIA15 Operating Instructions BA01170K.

6.1.2 With junction box

Max. operating voltage:	30 V
Max. operating current	30 mA

Wiring

1. Unscrew cover and remove.
 - ↳ The terminal assignment is indicated in the box.

2. Guide the cable cores through the M16 cable gland.
3. Connect cores in accordance with the assignment provided.

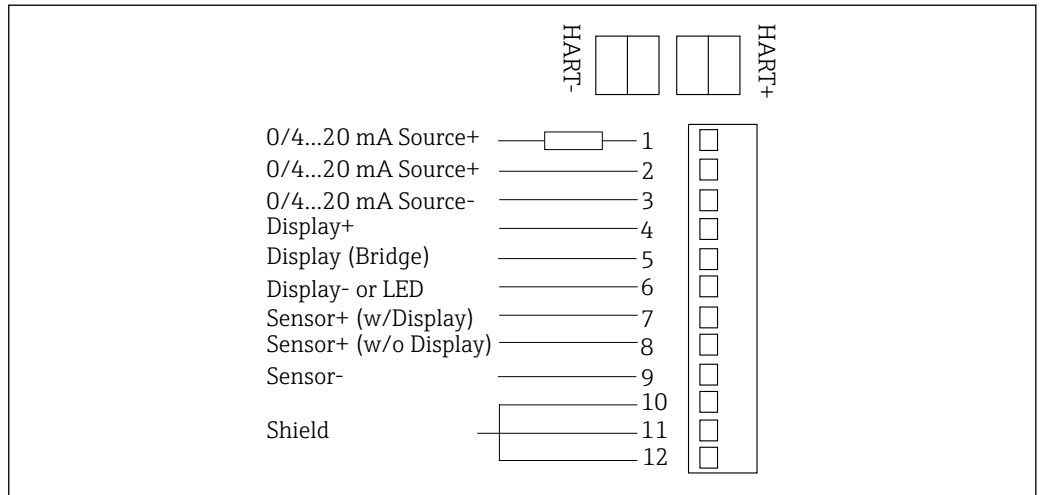

A0034718

4 Terminal diagram

Further information is available in the Operating Instructions BA01802C.

6.2 Post-connection check

WARNING

Connection errors

The safety of people and of the measuring point is under threat. The manufacturer does not accept any responsibility for errors that result from failure to comply with the instructions in this manual.

- ▶ Put the device into operation only if you can answer **yes** to **all** the following questions.

Electrical connection

- ▶ Is the device or cable undamaged (visual inspection)?
- ▶ Do the mounted cables have adequate strain relief?
- ▶ Are the cables routed without loops and cross-overs?
- ▶ Does the supply voltage match the specifications on the nameplate?
- ▶ No reverse polarity, is terminal assignment correct?

7 System integration

7.1 Integrating the measuring device into the system

Interface for measured value transmission:
4 to 20 mA

 For configuration with the measured value and the current output turndown, select the option in the order structure when ordering. This cannot be changed at a later stage.

8 Commissioning

8.1 Preparatory steps

- ▶ Connect the device.
 - ↳ The device starts up and transmits the measured value as a current value.

8.2 Function check

WARNING

Incorrect connection, incorrect supply voltage

Safety risks for staff and device malfunctions!

- ▶ Check that all connections have been established correctly in accordance with the wiring diagram.
- ▶ Ensure that the supply voltage matches the voltage indicated on the nameplate.

Familiarize yourself with the operation of the device before it is first switched on. In particular please read the "Basic safety instructions" sections. After power-up, the device performs a self-test and then goes to the measuring mode.

8.2.1 LED display

LED messages signal the status of the device and sensor.

LED behavior	Status
Green Flashes quickly	Everything OK Device starting up
Green Flashes twice	Everything OK Read out Memosens sensor information from sensor to transmitter (sensor type, calibration data, etc.)
Green Flashes slowly	Everything OK Sensor and device OK and functioning correctly.
Green Flashes quickly three times	Everything OK Measured value at PLC in automatic HOLD. If the "Sensor replacement alarm delay" is exceeded, the device transmits a signal on alarm. The automatic hold is set to 30 seconds.
Red Flashes quickly	Failure of device or sensor Fault state as per NAMUR NE107

9 Operation

9.1 Reading measured values

The measured value is output at the current output in accordance with the order code.

The LED indicates the status of the measuring point (→  14).

The data relating to the measuring point can be found on the nameplate. →  9

10 Diagnostics and troubleshooting

10.1 Diagnostic information via LED

See LED display in Commissioning section. (→  14)

11 Maintenance

The maintenance of the measuring point comprises:

- Calibration
- Cleaning the controller, assembly and sensor
- Checking the cables and connections.

⚠ WARNING

Process pressure and temperature, contamination

Risk of serious or fatal injury

- ▶ If the sensor has to be removed during maintenance work, avoid hazards posed by pressure, temperature and contamination.

NOTICE

Electrostatic discharge (ESD)

Risk of damaging the electronic components

- ▶ Take personal protective measures to avoid ESD, such as discharging beforehand at PE or permanent grounding with a wrist strap.

11.1 Maintenance tasks

11.1.1 Cleaning

NOTICE

Cleaning agents not permitted

Damage to housing surface and optical waveguide

- ▶ Never use concentrated mineral acids or alkaline solutions for cleaning.
- ▶ Never use organic cleaners such as acetone, benzyl alcohol, methanol, methylene chloride, tetrahydrofuran, xylene or concentrated glycerol cleaner.

The device is resistant to:

- Ethanol (for a short time)
- Diluted acids (max. 2% HCl)
- Diluted bases (max. 3% NaOH)
- Soap-based household cleaning agents
- Washing-up liquid

12 Repair

12.1 General notes

- ▶ Only use spare parts from Endress + Hauser to guarantee the safe and stable functioning of the device.

Detailed information on the spare parts is available at:

www.endress.com/device-viewer

12.2 Return

The product must be returned if repairs or a factory calibration are required, or if the wrong product was ordered or delivered. As an ISO-certified company and also due to legal regulations, Endress+Hauser is obliged to follow certain procedures when handling any returned products that have been in contact with medium.

To ensure the swift, safe and professional return of the device:

- ▶ Refer to the website www.endress.com/support/return-material for information on the procedure and conditions for returning devices.

12.3 Disposal

The device contains electronic components, and must therefore be disposed of in accordance with regulations on the disposal of electronic waste.

- ▶ Observe the local regulations.

13 Accessories

13.1 Sensors

13.1.1 Glass electrodes

Orbisint CPS11D

- pH electrode for process technology
- Optional SIL version for connecting to SIL transmitter
- With dirt-repellent PTFE diaphragm
- Product Configurator on the product page: www.endress.com/cps11d



Technical Information TI00028C

Memosens CPS31D

- pH electrode with gel-filled reference system with ceramic diaphragm
- Product Configurator on the product page: www.endress.com/cps31d



Technical Information TI00030C

Ceraliquid CPS41D

- pH electrode with ceramic junction and KCl liquid electrolyte
- Product Configurator on the product page: www.endress.com/cps41d



Technical Information TI00079C

Ceragel CPS71D

- pH electrode with reference system including ion trap
- Product Configurator on the product page: www.endress.com/cps71d



Technical Information TI00245C

Memosens CPS171D

- pH electrode for bio-fermenters with digital Memosens technology
- Product Configurator on the product page: www.endress.com/cps171d



Technical Information TI01254C

Orbipore CPS91D

- pH electrode with open aperture for media with high dirt load
- Product Configurator on the product page: www.endress.com/cps91d



Technical Information TI00375C

Orbipac CPF81D

- Compact pH sensor for installation or immersion operation
- In industrial water and wastewater
- Product Configurator on the product page: www.endress.com/cpf81d



Technical Information TI00191C

13.1.2 Enamel pH electrodes

Ceramax CPS341D

- pH electrode with pH-sensitive enamel
- Meets highest demands of measuring accuracy, pressure, temperature, sterility and durability
- Product Configurator on the product page: www.endress.com/cps341d



Technical Information TI00468C

13.1.3 ORP sensors

Orbisint CPS12D

- ORP sensor for process technology
- Product Configurator on the product page: www.endress.com/cps12d

 Technical Information TI00367C

Ceraliquid CPS42D

- ORP electrode with ceramic junction and KCl liquid electrolyte
- Product Configurator on the product page: www.endress.com/cps42d

 Technical Information TI00373C

Ceragel CPS72D

- ORP electrode with reference system including ion trap
- Product Configurator on the product page: www.endress.com/cps72d

 Technical Information TI00374C

Orbipac CPF82D

- Compact ORP sensor for installation or immersion operation in process water and wastewater
- Product Configurator on the product page: www.endress.com/cpf82d

 Technical Information TI00191C

Orbipore CPS92D

- ORP electrode with open aperture for media with high dirt load
- Product Configurator on the product page: www.endress.com/cps92d

 Technical Information TI00435C

13.1.4 pH ISFET sensors

Tophit CPS441D

- Sterilizable ISFET sensor for low-conductivity media
- Liquid KCl electrolyte
- Product Configurator on the product page: www.endress.com/cps441d

 Technical Information TI00352C

Tophit CPS471D

- Sterilizable and autoclavable ISFET sensor for food and pharmaceuticals, process engineering
- Water treatment and biotechnology
- Product Configurator on the product page: www.endress.com/cps471d

 Technical Information TI00283C

Tophit CPS491D

- ISFET sensor with open aperture for media with high dirt load
- Product Configurator on the product page: www.endress.com/cps491d

 Technical Information TI00377C

13.1.5 pH and ORP combined sensors

Memosens CPS16D

- Combined pH/ORP sensor for process technology
- With dirt-repellent PTFE diaphragm
- With Memosens technology
- Product Configurator on the product page: www.endress.com/cps16D

 Technical Information TI00503C

Memosens CPS76D

- Combined pH/ORP sensor for process technology
- Hygienic and sterile applications
- With Memosens technology
- Product Configurator on the product page: www.endress.com/cps76d

 Technical Information TI00506C

Memosens CPS96D

- Combined pH/ORP sensor for chemical processes
- With poison-resistant reference with ion trap
- With Memosens technology
- Product Configurator on the product page: www.endress.com/cps96d

 Technical Information TI00507C

13.1.6 Conductivity sensors with conductive measurement of conductivity

Condumax CLS15D

- Conductive conductivity sensor
- For pure water, ultrapure water and Ex applications
- Product Configurator on the product page: www.endress.com/CLS15d

 Technical Information TI00109C

Condumax CLS16D

- Hygienic, conductive conductivity sensor
- For pure water, ultrapure water and Ex applications
- With EHEDG and 3A approval
- Product Configurator on the product page: www.endress.com/CLS16d

 Technical Information TI00227C

Condumax CLS21D

- Two-electrode sensor in plug-in head version version
- Product Configurator on the product page: www.endress.com/CLS21d

 Technical Information TI00085C

Memosens CLS82D

- Four-electrode sensor
- With Memosens technology
- Product Configurator on the product page: www.endress.com/cls82d

 Technical Information TI01188C

13.1.7 Oxygen sensors

Oxymax COS22D

- Sterilizable sensor for dissolved oxygen
- With Memosens technology or as an analog sensor
- Product Configurator on the product page: www.endress.com/cos22d



Technical Information TI00446C

Oxymax COS51D

- Amperometric sensor for dissolved oxygen
- With Memosens technology
- Product Configurator on the product page: www.endress.com/cos51d



Technical Information TI00413C

Memosens COS81D

- Sterilizable, optical sensor for dissolved oxygen
- With Memosens technology
- Product Configurator on the product page: www.endress.com/cos81d



Technical Information TI01201C

13.2 Software

Memobase Plus CYZ71D

- PC software to support laboratory calibration
- Visualization and documentation of sensor management
- Sensor calibrations stored in database
- Product Configurator on the product page: www.endress.com/cyz71d



Technical Information TI00502C

13.3 Other accessories

13.3.1 Activation codes



You must quote the serial number of the device when ordering the activation code.

Activation code: Bluetooth

Order No. 71401176

13.3.2 Cable junction with Velcro strip

Cable junction with Velcro strip

- 4 pieces, for sensor cable
- Order No. 71092051

13.3.3 Communication-specific accessories

Commubox FXA195

Intrinsically safe HART communication with FieldCare via the USB port



Technical Information TI00404F

Wireless HART adapter SWA70

- Wireless device connection
- Easily integrated, offers data protection and transmission safety, can be operated in parallel with other wireless networks, minimum cabling complexity



Technical Information TI00061S

13.3.4 System components**RIA15**

- Process display unit, Digital display unit for integration into 4-20 mA circuits
- Panel mounting
- With optional HART communication



Technical Information TI01043K

14 Technical data

14.1 Input

Measured variables

- pH
- ORP
- pH/ORP
- Oxygen
- Conductivity

Measuring ranges

→ Documentation of the connected sensor

Types of input

Digital sensor inputs for Memosens-sensors

Cable specification

Cable length:

- Max. 3 m (10 ft)
- Max. 7 m (23 ft)
- Max. 15 m (49 ft)

14.2 Output

Output signal

4 ... 20 mA, galvanically isolated from the sensor circuits

Linearization/transmission behavior

Linear

14.3 Power supply

Supply voltage

12.6 to 30 VDC (with setting error current > 20 mA)

14 to 30 VDC (with setting error current < 4 mA)

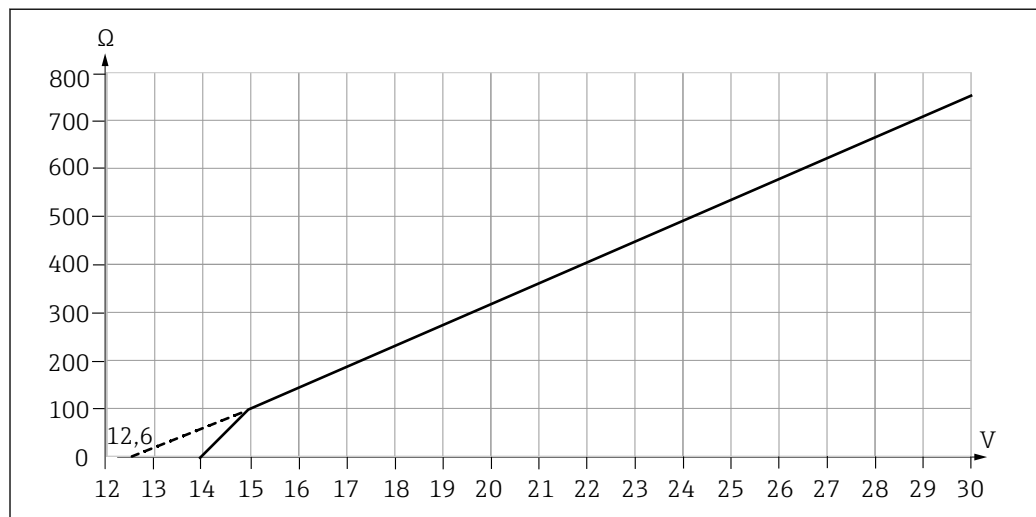

5 Supply voltage and load

A0036752

The lower voltage value in each case applies only to a load resistance of 0 Ohm.

NOTICE

The device does not have a power switch

- ▶ At the supply point, the power supply must be isolated from dangerous live cables by double or reinforced insulation in the case of devices with a 24 V power supply.

Overvoltage protection IEC 61 000-4-4 and IEC 61 000-4-5 with +/- 1 kV

Sensor connection *Sensors with Memosens protocol*

Sensor types	Sensors
Digital Sensors with inductive memosens plug head	<ul style="list-style-type: none"> ▪ pH sensors ▪ ORP sensors ▪ pH/ORP combination sensors ▪ Oxygen sensors ▪ Conductivity sensors

14.4 Performance characteristics

Response time of current output t_{90} = max. 500 ms for an increase from 0 to 20 mA

Tolerance of current output **Typical measuring tolerances:**
 < ±20 µA (if current value = 4 mA)
 < ±50 µA (for current values 4 to 20 mA)
 at 25 °C (77 ° F) each
additional tolerance depending on the temperature:
 < 1.5 µA/K

Resolution of current output < 5 µA

Repeatability → Documentation of the connected sensor

14.5 Environment

Ambient temperature -20 to +85 °C (0 to 185 °F)

 The maximum ambient temperature depends on the process temperature and the installation situation of the transmitter.

Make sure that the ambient temperature at the transmitter does not exceed +85 °C (185 °F).

Example of environmental conditions in Endress+Hauser fittings:

- with open installation (without protective cover, i.e. free convection at the transmitter), e.g. CPA442, CPA842
- for enclosed installation (with protective cover), e.g. CPA871, CPA875, CPA842

$T_{ambient}$ = max. 60 °C (140 °F)

$T_{prozess}$ = max. 100 °C (212 °F), in continuous operation

$T_{\text{prozess}} = \text{max. } 140 \text{ }^{\circ}\text{C} (284 \text{ }^{\circ}\text{F}), < 2\text{h (for sterilization)}$

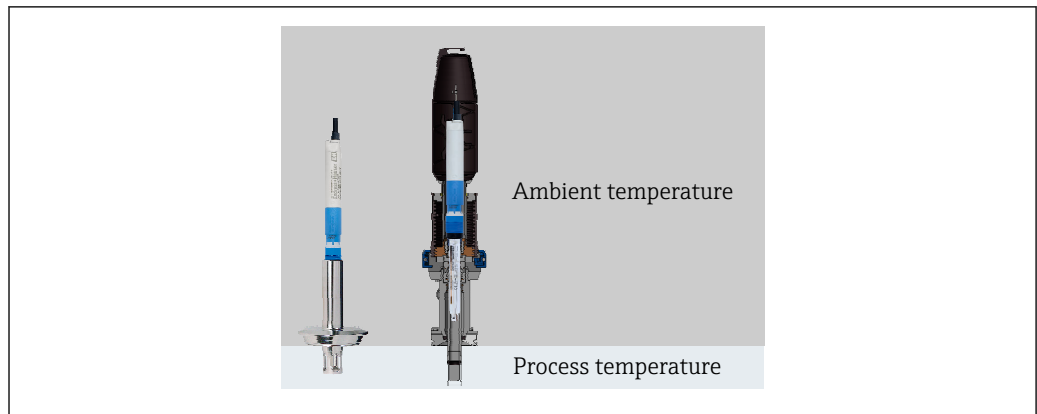

A0036933-EN

6 Mounting situation of the transmitter with or without protective cover

Storage temperature -40 to +85 °C (-40 to 185 °F)

Humidity 5 to 95 %

Degree of protection IP 67
IP 68
NEMA Type 6

Electromagnetic compatibility

- EN 61326-1
- EN 61326-2-3
- NAMUR NE 21

Electrical safety EN 61010-1

Max. altitude above MSL < 2000 m (< 6562 ft) above MSL

Degree of contamination	Complete device:	Pollution level 4
	Internal:	Pollution level 2

14.6 Mechanical construction

Materials	Components	Material
		Housing, cover
	Strain relief	EPDM (peroxide crosslinked)
	Axial ring	Peek 450 G
	Optical waveguide	PC transparent

Impact loads

The product is designed for mechanical impact loads of 1 J (IK06) as per the requirements of EN61010-1.

Weight

without cable	Approx. 42 g (1.5 oz)
3 m (9 f) cable	Approx. 190 g (7 oz)
7 m (23 f) cable	Approx. 380 g (13 oz)
15 m (49 f) cable	Approx. 760 g (27 oz)
For every 1 m (3 f) of cable	Approx. 48 g (2 oz)

Index

A

Accessories	19
Communication-specific	22
Activation codes	19
Ambient temperature	25
Approvals	10

C

Cable specification	24
Calibration	17
Certificates	10
Check	
Installation and function	14
Cleaning	17
Commissioning	14
Connection	
Electrical	12
Sensors	25
Supply voltage	24
connection with RIA15	12

D

Degree of contamination	26
Degree of protection	26
Designated use	6
Diagnostics	16
Dimensions	11
Disposal	18
Documentation	5

E

Electrical connection	12
Electrical safety	26
Electromagnetic compatibility	26

F

Function check	14
--------------------------	----

H

Humidity	26
--------------------	----

I

Incoming acceptance	9
Input	
Measured variables	24
Installation	11

L

LED display	14
Linearization	24

M

Maintenance	17
Maintenance tasks	17
Materials	26
Measured variables	24
Measuring parameters	8

Measuring ranges	24
----------------------------	----

N

Nameplate	9
---------------------	---

O

Occupational safety	6
Operation	15
Operational safety	6
Output signal	24
Overvoltage protection	25

P

Post-connection check	13
Post-installation check	14
Power supply	24
Overvoltage protection	25
Sensor connection	25
Supply voltage	24
Product description	8
Product design	8
Product identification	9

R

Repair	18
Requirements for personnel	6
Return	18

S

Safety	
Occupational safety	6
Operation	6
Safety instructions	6
Scope of delivery	10
Sensor	
Connection	25
Sensors	19
Software	19
Storage temperature	26
Supply voltage	24
Symbols	4
System integration	14

T

Technical data	24
Environment	25
Input	24
Mechanical construction	26
Output	24
Technical personnel	6
Transmission behavior	24
Troubleshooting	16
Types of input	24

U

Use	
Designated	6

W

Warnings 4

www.addresses.endress.com
